

# DATASHEET AND OPERATING GUIDE

# LDxCHA Series

## Low Noise up to 15 A / 28 V Laser Diode Drivers



### FEATURES AND BENEFITS

- Models: 2.5 A, 5 A, 10 A, and 15 A
- Single supply operation at +5 VDC for single emitters (3 V maximum to laser)
- Dual supply operation up to +30 VDC (28 V maximum to laser)
- Constant Current or Constant Power modes
- Safety features protect your laser
  - » Adjustable clipping current limit
  - » Slow-start and delay circuitry
  - » Brownout protection
  - » Over-voltage protection
- Bandwidth 280 kHz to 1 MHz in Constant Current mode (model dependent)
- RMS Noise Current as low as 7  $\mu$ A at 100 kHz

### MEETING LASER REQUIREMENTS

The LDxCHA product family has current levels from 2.5 A up to 15 A. These drivers meet laser compliance requirements from 3 V with a single +5 V supply, and up to 28 V with an additional 30 V power supply, supporting applications such as materials processing, industrial laser cutting, and laser diode bars/stacks. This product family supports A & B type laser diodes.

### WORRY-FREE SETUP

The new circuitry in the LDxCHA allows for the laser diode current limit and the laser diode current setpoint to be fine-tuned without output current enabled to the laser. This allows users to set the specific safety and output levels required without risk of overdriving the laser during initial configuration.

### DESIGNED FOR EASY INTEGRATION

The LDxCHA drivers, with their small size and easy mountability, can be attached directly to an optics table or designed into a system. Two trimpots set the current limit and current setpoint, while five screw terminal blocks allow for simple wiring.

### LASER SAFETY FEATURES

Built-in safety features ensure robust designs for real world operating conditions: clipping current limit ensures that the output current will never exceed the setpoint; and slow start circuit ramps the output current. Long-term reliability means better up-time, fewer service calls, and more satisfied customers.

### CONTENTS

	PAGE
QUICK CONNECT GUIDE	2
PIN DESCRIPTIONS	4
ELECTRICAL SPECIFICATIONS	6
SAFETY INFORMATION	8
OPERATING INSTRUCTIONS	9
ADDITIONAL TECHNICAL INFORMATION	15
TROUBLESHOOTING	21
MECHANICAL SPECIFICATIONS	23
CERTIFICATION AND WARRANTY	24

### ORDERING INFORMATION

PART NO	DESCRIPTION
LD2.5CHA	2.5 A Laser Diode Driver
LD5CHA	5 A Laser Diode Driver
LD10CHA	10 A Laser Diode Driver
LD15CHA	15 A Laser Diode Driver
PWRPAK-16A-5V	16 A / 5 V Switching Power Supply
WCB325	Power Supply Wiring Kit



406-587-4910

[www.teamWavelength.com](http://www.teamWavelength.com)

© June 2021  
Applies to Product Revisions A-B



**WAVELENGTH**  
ELECTRONICS



Figure 3 illustrates the two laser types that the LDxCHA can drive. For detailed instructions on using the different laser types refer to the **Operating Instructions**.

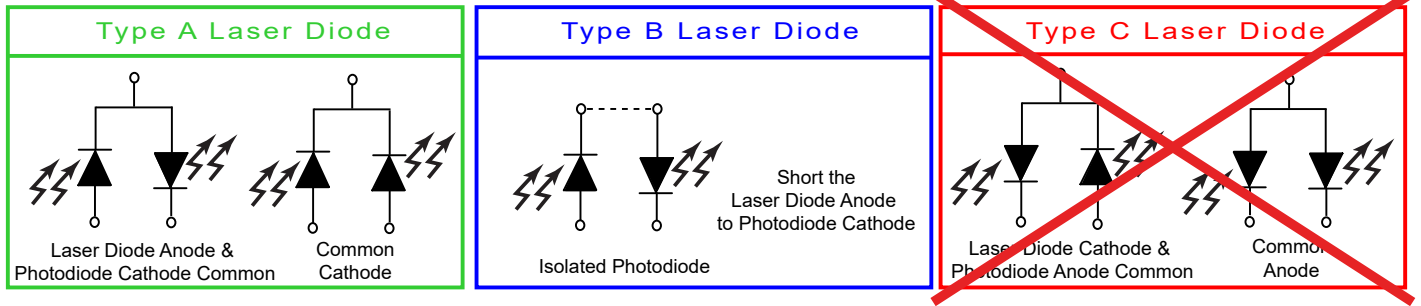
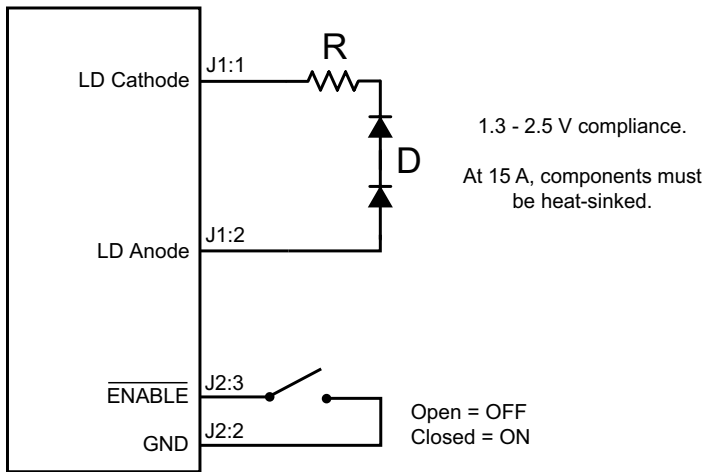

Figure 3. Laser Type Diagrams

**RECOMMENDED TEST LOAD – CONSTANT CURRENT MODE**

For initial setup and configuration, we recommend using a test load with the LDxCHA; refer to **Figure 4**. When using the test load, the actual drive current can be determined by measuring the voltage drop across the resistor. Do not place an ammeter in series with the laser.



CURRENT	RESISTOR (R)	DIODE (D)
1 A	1.0 Ω, 2 W	1N4001 (×2)
5 A	0.1 Ω, 5 W	80SQ030 (×3)
15 A	0.05 Ω, 100W	STPS20M100ST (×2)

Figure 4. Constant Current Mode Laser Test Load (up to 15 A)

## PIN DESCRIPTIONS

Table 1. Pin Descriptions

PIN	NAME	PIN DESCRIPTION
<b>Connector J1 – Power &amp; Laser Diode Connections</b>		
1	LDC	Connect this pin to the Laser Diode Cathode.
2	LDA	Connect this pin to the Laser Diode Anode. This pin is internally connected to V+.
3	V+	This pin is the main power supply pin for single and dual supply operation. Allowable voltage input is 5 to 30 V. It is internally connected to the laser diode anode (LDA). <i>If using a +5 V power supply, you can install jumper JP2 to power the control electronics from the same supply. If using a higher voltage power supply for more compliance voltage to the laser diode, remove JP2.</i> <sup>1</sup>
4	GND	Used for high current return. This pin is internally connected to pin J5:2.
<b>Connector J2 – Status Connections &amp; Modulation Input</b>		
1	MOD INPUT	Use this pin to allow for modulation. Range is -2 V to +5 V. This signal sums with the onboard trimptot. <i>If no modulation, install jumper JP1.</i> <sup>1</sup> Modulation Input Impedance is 2.5 kΩ.
2	GND	This pin is the ground reference for modulation. Not to be used for high current return.
3	$\overline{\text{ENABLE}}$	TTL compatible input that allows remote enabling and disabling of current to the laser diode. To enable current, the voltage at this pin must be <0.3 V. To disable current, the voltage at this pin must be >2 V. The enable circuit uses an internal 10 kΩ pullup resistor. For the LDxCHA to enable output current to the laser, the ENABLE pin must be configured properly. If the ENABLE pin is not at a voltage <0.3 V, the LDxCHA <i>will not</i> enable current to the laser. The internal pullup resistor will hold this pin high if it is left floating.
4	LIM MON	Monitors the current limit set by the user. Outputs a voltage proportional to the current limit. See <b>Table 2</b> for model-specific transfer function. Range is 0 to 2.5 V on monitor.
5	LD STATUS	Monitors whether output current is enabled to the laser diode. If output is enabled, there will be +5 V at this pin. If output is disabled, there will be 0 V at this pin.
6	GND	This pin is the ground reference for $\overline{\text{ENABLE}}$ , LIM MON, and LD STATUS. Not to be used for high current return.
<b>Connector J3 – Monitor Connections</b>		
1	SET MON	Monitors the user-defined setpoint. Outputs a voltage proportional to the current setpoint. See <b>Table 2</b> for model-specific transfer function. Range is 0 to 2.5 V on monitor.
2	I MON	Monitors the output current. Outputs a voltage proportional to the current through the laser diode. See <b>Table 2</b> for model-specific transfer function. Range is 0 to 2.5 V on monitor.
3	P MON	Monitors the photodiode output. Outputs a voltage proportional to the current through the photodiode. See <b>Table 2</b> for model-specific transfer function. Range is 0 to 2.5 V on monitor.
4	GND	This pin is the ground reference for the monitors on connector J3. Not to be used for high current return.
<b>Connector J4 – Photodiode Connections</b>		
1	PDC	Connect this pin to the Photodiode Cathode. <i>The photodiode must be connected to the laser diode. See jumper JP3.</i> <sup>1</sup>
2	PDA	Connect this pin to the Photodiode Anode.
<b>Connector J5 – Control Electronics Connections</b>		
1	+5V	Connect +5 VDC to this pin to power control electronics. Do not exceed 5.5 V at this pin. <i>If single +5 V supply operation is used, install JP2 and only connect the power supply to J1.</i>
2	GND	This pin is the ground reference for +5V. Not to be used for high current return. This pin is internally connected to pin J1:4.

<sup>1</sup> For more details regarding jumpers, see **Table 3 on page 5** and “**Install or Remove Jumpers**” on page 12.

**Table 2. Current Output Monitor, Limit Monitor, Photodiode Current Monitor, and Modulation Input Transfer Functions**

FUNCTION	MODE	LABEL	LD2.5CHA	LD5CHA	LD10CHA	LD15CHA
I LIM MON, Current Limit Setpoint Monitor*	CC / CP	$V_{ILIMMON}$	1 A / V	2 A / V	4 A / V	6 A / V
I SET MON, Current Setpoint Monitor	CC	$V_{ISETMON}$	1 A / V	2 A / V	4 A / V	6 A / V
I MON, Output Current Monitor	CC / CP	$V_{IMON}$	1 A / V	2 A / V	4 A / V	6 A / V
Modulation Input, CC-Mode	CC		0.5 A / V	1 A / V	2 A / V	3 A / V
P MON, Photodiode Current Monitor (500 $\mu$ A setting)	CP	$V_{PMON}$	200 $\mu$ A / V			
P MON, Photodiode Current Monitor (5 mA setting)	CP	$V_{PMON}$	2 mA / V			
P MON, Photodiode Current Monitor (100 mA setting)	CP	$V_{PMON}$	40 mA / V			

\* The I LIM MON transfer function is accurate above 5% of maximum current available from the unit.

**Table 3. Description of jumper connections and functionality.**

JUMPER	CONNECTS	FUNCTION
JP1	MOD INPUT to GND (J2:1 to J2:2)	If installed, ties modulation input to ground, disabling modulation functionality and minimizing output current noise. Remove this jumper if external modulation is required.  Unit ships with JP1 <i>installed</i> .
JP2	V+ to +5V (J1:3 to J5:1)	If installed, ties V+ to +5V, allowing for operation from a single +5 V supply. Maximum voltage to the laser diode in this case is 3 V.  If uninstalled, allows for high compliance operation from two separate power supplies: one at +5 V to power control electronics, and one from +5 V to +30 V for higher voltage to the laser diode. Maximum voltage to the laser diode in this case is 28 V (using a +30 V supply).  Unit ships with JP2 <i>installed</i> .
JP3	PDC to LDA (J4:1 to J1:2)	If installed, ties Photodiode Cathode to Laser Diode Anode for Constant Power operation.  <b>TYPE B:</b> This jumper <i>must be installed</i> to operate a Type B (Isolated Photodiode) laser diode in Constant Power Mode. <b>TYPE A:</b> This jumper <i>must be removed</i> to operate a common Photodiode Cathode/Laser Diode Cathode Type A laser diode or a common Photodiode Cathode/Laser Diode Anode Type A laser. If the jumper is not removed, damage may occur.  Consult the laser manual to determine if this connection is already made internally.  Unit ships with JP3 <i>installed</i> .

## ELECTRICAL SPECIFICATIONS

PARAMETER	SYMBOL	VALUE	UNIT	NOTE
<b>ABSOLUTE MAXIMUM RATINGS</b>				
Control Electronics Voltage (J5:1)	+5V	4.8 to 5.5	VDC	Undervoltage trip is 4 V. Overvoltage trip is 6 V.
Supply Voltage, (J1:3)	V+	5 to 30	VDC	
Current Limit Range	LIM	0.05 to Maximum	A	Maximum current is model specific
Operating Temperature Range	T <sub>OPR</sub>	0 to 40	°C	
Storage Temperature Range	T <sub>STG</sub>	-55 to 125	°C	
Weight		4	oz	113 grams
Size		1.125 x 2.1 x 4.5	in	28.6 mm x 53.3 mm x 114.3 mm

PARAMETER	MODEL				UNIT	NOTE
	LD2.5CHA	LD5CHA	LD10CHA	LD15CHA		
<b>DRIVE CURRENT OUTPUT</b>						
Max Internal Power Dissipation (No Airflow)	25	25	50	60	W	25°C ambient
Max Internal Power Dissipation (With Airflow)	35	35	70	85	W	25°C ambient, 5.5 CFM: 2.5, 5 A models 12 CFM: 10, 15 A models
Max Output Current	2.5	5	10	15	A	
Compliance Voltage <sup>1</sup>	3 V max with 5 V power supply input 28 V max with 30 V power supply input				V	Compliance Voltage is always 2 V less than power supply voltage
Short Term Stability, 1 hour	< 200				ppm	Constant Current Mode
RMS Noise Current	7	9	22	35	µA	At 100 kHz, with 500 mA output current
Noise Current Density	20	35	95	100	nA / √Hz	At 500 mA output current
Quiescent Current	130				mA	
Leakage Current	0				µA	
Temperature Coefficient	100				ppm / °C	
<b>PHOTODIODE FEEDBACK</b>						
Ranges	500 µA, 5 mA, or 100 mA					Set by PD RANGE DIP switches
Constant Power Mode Output Stability	0.14	0.27	0.03	0.03	%	At 200 µA photodiode range, simulated load
<b>EXTERNAL MODULATION</b>						
Modulation Input Damage Threshold	$V_{MOD} \leq -3$ or $V_{MOD} \geq 8$				V	
Modulation Input Range	-2 to +5				V	
Modulation Input Pin Impedance	2.5				kΩ	
-3 dB Bandwidth at Half Current, Constant Current Mode	580	600	530	390	kHz	Sine wave input
-3 dB Bandwidth at Full Current, Constant Current Mode	1080	1000	660	600	kHz	Sine wave input
Bandwidth at 90% Depth of Modulation at Half Current	1000	430	360	280	kHz	Constant Current Mode Square wave input
Bandwidth at 90% Depth of Modulation at Full Current	680	580	480	400	kHz	Constant Current Mode Square wave input
Output Rise Time (Full Current)	0.8	0.8	1.4	1.4	µsec	At 10 kHz
Output Fall Time (Full Current)	0.76	0.78	1.2	1.2	µsec	At 10 kHz

1. Compliance voltage depends on power supply voltage. In high-compliance mode, up to 30 VDC can be input at V+ to achieve up to 28 V (compliance voltage) across the laser diode. A separate 5 VDC power supply is then required for the +5V control electronics pin. A 5 VDC power supply input at V+ results in 3 V compliance voltage.

## ELECTRICAL SPECIFICATIONS (CONTINUED)

PARAMETER	MODEL				UNIT	NOTE
	LD2.5CHA	LD5CHA	LD10CHA	LD15CHA		
<b>TIMING CHARACTERISTICS</b>						
Warm Up Time	1				hour	
Slow Start Delay	2				sec	CDRH compliant
Slow Start Ramp	20				msec	To full scale
Disable Fall Time	640				μsec	
Turn Off Ramp	260				μsec	
<b>MONITOR ACCURACY</b>						
Monitor Voltage vs. Expected Output based on transfer function	0.27	0.64	0.52	0.75	% of Full Scale	

## SAFETY INFORMATION

### SAFE OPERATING AREA – DO NOT EXCEED INTERNAL POWER DISSIPATION LIMITS

Before attempting to operate the LDxCHA driver, it is imperative that you first determine that the unit will operate within the *Safe Operating Area* (SOA). Operating outside of the SOA may damage the laser and the LDxCHA. Operating outside of the SOA will void the warranty.

To determine if the LDxCHA driver will be operating in a safe range, follow the instructions for calculating the Safe Operating Area online with your system's voltages and current requirements:

[www.teamwavelength.com/support/design-tools/soa-ld-calculator/](http://www.teamwavelength.com/support/design-tools/soa-ld-calculator/)

SOA charts are included in this datasheet for quick reference (**page 19**), but we recommend you use the online tools instead.



TO ENSURE SAFE OPERATION OF THE LDxCHA DRIVER, IT IS IMPERATIVE THAT YOU DETERMINE IF THE UNIT IS GOING TO BE OPERATING WITHIN THE INTERNAL HEAT DISSIPATION SAFE OPERATING AREA (SOA).

If you have any questions about the Safe Operating Area calculator, call the factory for free and prompt technical assistance.

### HEAT SINK TEMPERATURE

For single supply, 5 V operation of the LD15CHA, the MULTI-HTSK-HI with recommended airflow is adequate up to 15 A operation. However, when using a second power supply to allow higher voltage operation, the MULTI-HTSK-HI heatsink temperature can exceed 50°C. If operating the LD15CHA under these conditions, a user supplied higher capacity heatsink is required for safe operation.

## THEORY OF OPERATION

The LDxCHA Series drivers are voltage controlled current sources: they deliver the current commanded by the setpoint. The control system continually monitors the actual output current, compares it to the setpoint, and adjusts the current if there is a difference between the two signals.

It may be useful to remember that you do not directly set the drive current setpoint; instead, you adjust a voltage signal that represents the output current. The voltage and output current are related by a transfer function that varies by driver model number and maximum current.

The setpoint voltage is adjusted with the onboard trimpot or by an external modulation input that sums with the onboard setpoint. The adjustable current limit is set using an onboard trimpot.

As current is driven through the load, there is a voltage drop across the load because of its impedance. As the current increases, the voltage drop may increase to the point that it reaches the Compliance Voltage limit of the current source. Once that occurs, the current source is no longer able to increase the current driven to the load even if you increase the setpoint.

The LDxCHA driver includes features that help protect your laser and make the driver more versatile in a wide array of applications:

- The user-adjustable clipping current limit protects the laser from over-current situations by never allowing the output current to exceed the user-set limit. If the setpoint is greater than the limit, the LDxCHA will hold the output current at or slightly below the limit.
- Both the current setpoint and the current limit can be set prior to enabling current to the laser diode.
- Output current switches on after a 2 second delay from the time the enable signal is applied, meeting CDRH requirements.
- Output slow-start ramps the current to setpoint over 20 msec.
- The ENABLE pin must be held low in order to have current enabled from the laser driver. If this pin is left floating, an internal pullup circuit will hold the pin high, disabling current output.
- Over/Under voltage shutdown protection ensures that output current will not be enabled if proper voltage is not supplied.
- Low noise: down to 7  $\mu$ A RMS noise current at 100 kHz.



## OPERATING INSTRUCTIONS

The LDxCHA requires no external electronic components.

These instructions first configure the driver for local control in order to set the drive current limit. Then the driver can be configured to your application.

We recommend using a test load until you are familiar with operation of the driver. Refer to **page 3** for a test load schematic.

## NECESSARY EQUIPMENT

The following equipment is the minimum necessary to configure the LDxCHA for basic operation:

- LDxCHA controller
- Digital voltmeter, 4-½ digit resolution recommended
- Test load for configuring the driver
- Laser diode, mount, and optional temperature control system
- Recommended heat sink
  - » For LD2.5CHA and LD5CHA, use the MULTI-HTSK
  - » For the LD10CHA and LD15CHA, use the MULTI-HTSK-HI
- Connecting wires
- Power supply (see below)

## POWER SUPPLY REQUIREMENTS

Linear-regulated or low-noise switching power supplies can be used. We recommend using power supplies with noise specifications suitable for your application.

For single-supply operation:

- 5 VDC power supply rated for 1.1-times the maximum laser diode current, plus 150 – 250 mA for the electronics

For dual supply operation to drive a high compliance laser diode, laser diode bar, or laser diode stack:

- 5 VDC power supply rated for 250 mA for electronics
- AND a power supply to drive the laser; rated for 1.1-times the maximum laser diode drive current and 2 V greater than the compliance voltage required by the laser, up to 30 V.

## PREVENT DAMAGE FROM ELECTROSTATIC DISCHARGE

Before proceeding, it is critical that you take precautions to prevent electrostatic discharge (ESD) damage to the driver and your laser. ESD damage can result from improper handling of sensitive electronics, and is easily preventable with simple precautions.

For more information on ESD, see Application Note [AN-LDTC06: Basics: Electrostatic Discharge \(ESD\)](#).

We recommend that you always observe ESD precautions when handling the LDxCHA driver and your laser diode.

Note: The LDxCHA case is isolated from electrical ground.

## WIRE THE LDxCHA LASER DRIVER

There are two possible wiring configurations for the LDxCHA, one for single supply operation, and one for dual supply operation. The figures on the next page serve as a guide for these two configurations. For setup and initial configuration, use a test load (see **Figure 4**).

Each of the terminal blocks on the LDxCHA are screw-in terminal blocks. To attach the necessary wires to the unit, simply loosen the screw, insert the wire into the proper slot, and then tighten the screw to securely fasten the wire to the LDxCHA.

For the power supply and laser diode connections (J1), it is recommended to use stranded 18 gauge wire for currents up to 5 A. For current levels greater than 5 A, stranded 14 gauge wire is recommended. The largest size that will fit into the J1 terminal block is 12 gauge.

For the remaining terminal blocks (J2 - J5), Wavelength recommends using 24 gauge solid core wire.

WIRING THE LDXCHA FOR SINGLE SUPPLY OPERATION

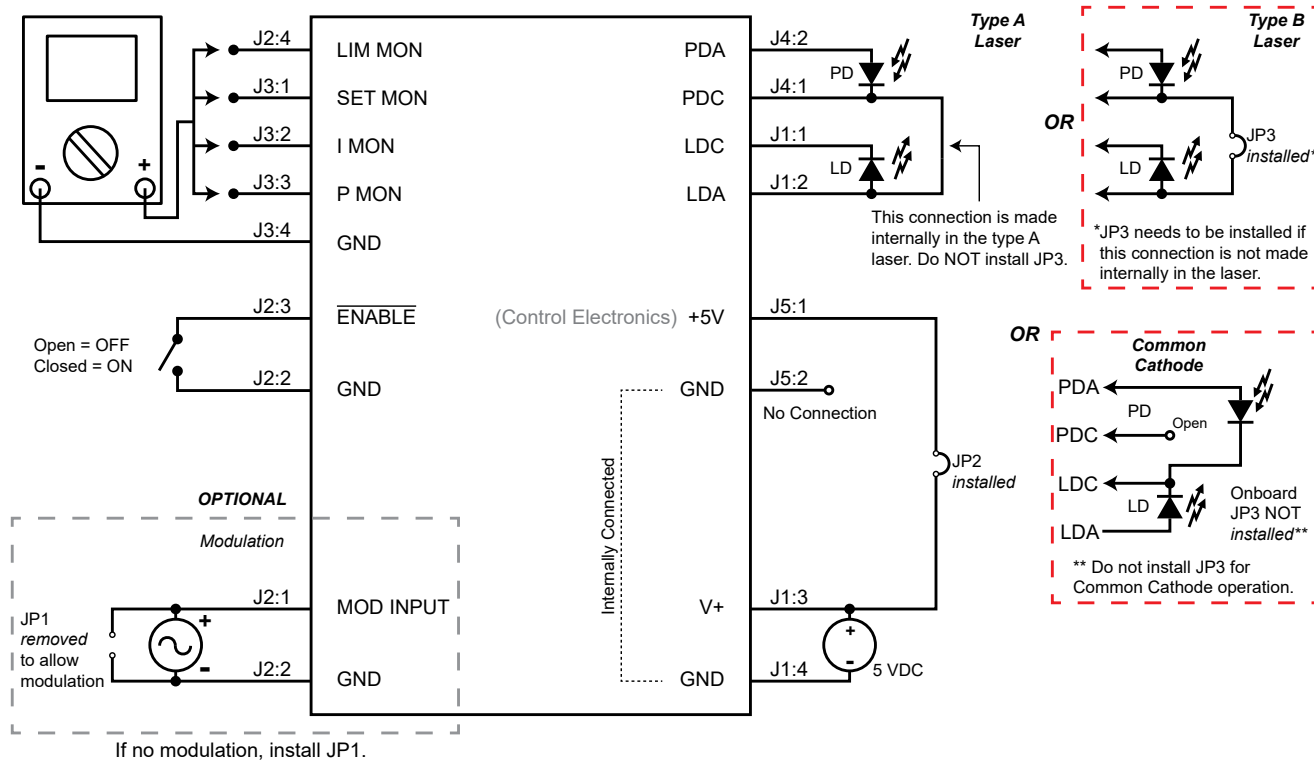

Figure 5. Type A & B Laser Diode, Single 5 VDC Power Supply, 3 V compliance maximum to the laser diode. All jumpers shown are either installed or uninstalled on the LDXCHA board.

WIRING THE LDXCHA FOR DUAL SUPPLY OPERATION

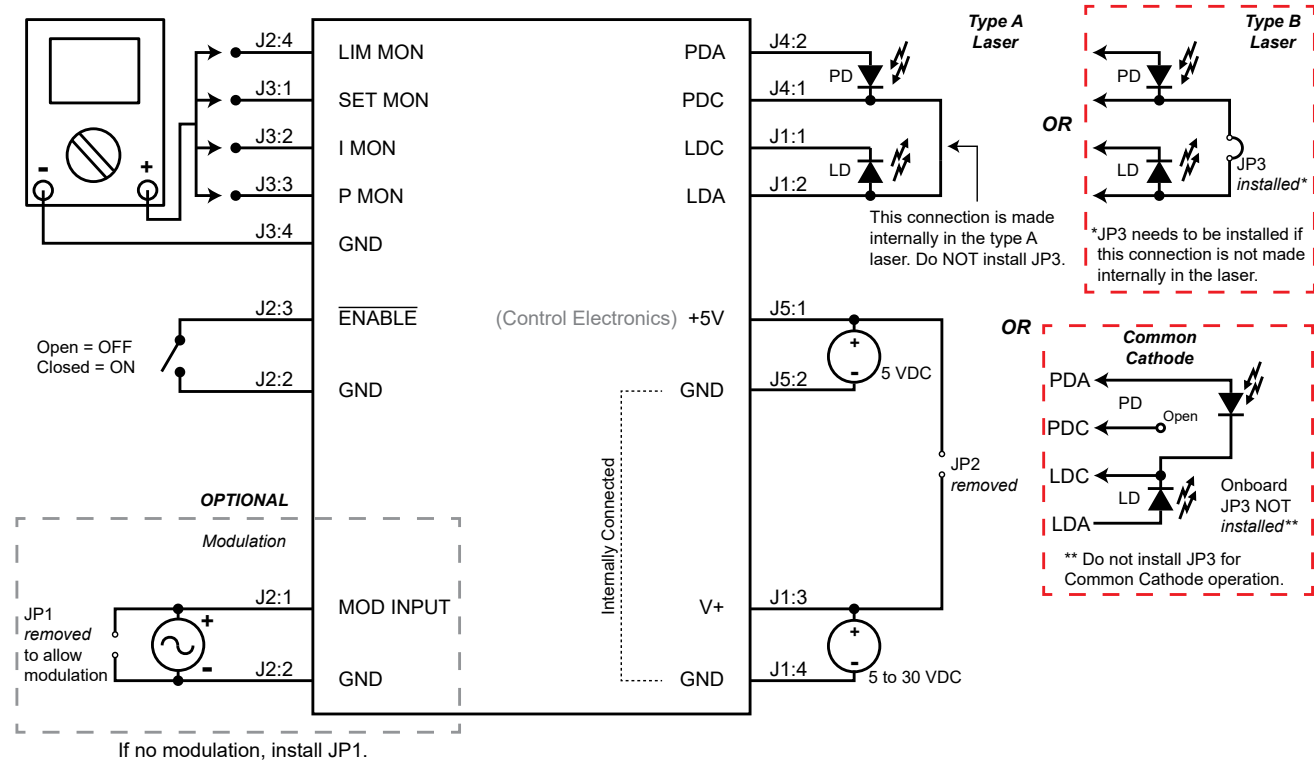

Figure 6. Type A & B Laser Diode, High Compliance Dual Supply Operation, up to 28 V compliance to the laser diode. All jumpers shown are either installed or uninstalled on the LDXCHA board.

ONBOARD ADJUSTMENTS AND CONTROLS

Onboard controls are on the top of the LDxCHA and must be set according to the operation mode. The controls are illustrated in **Figure 7**.

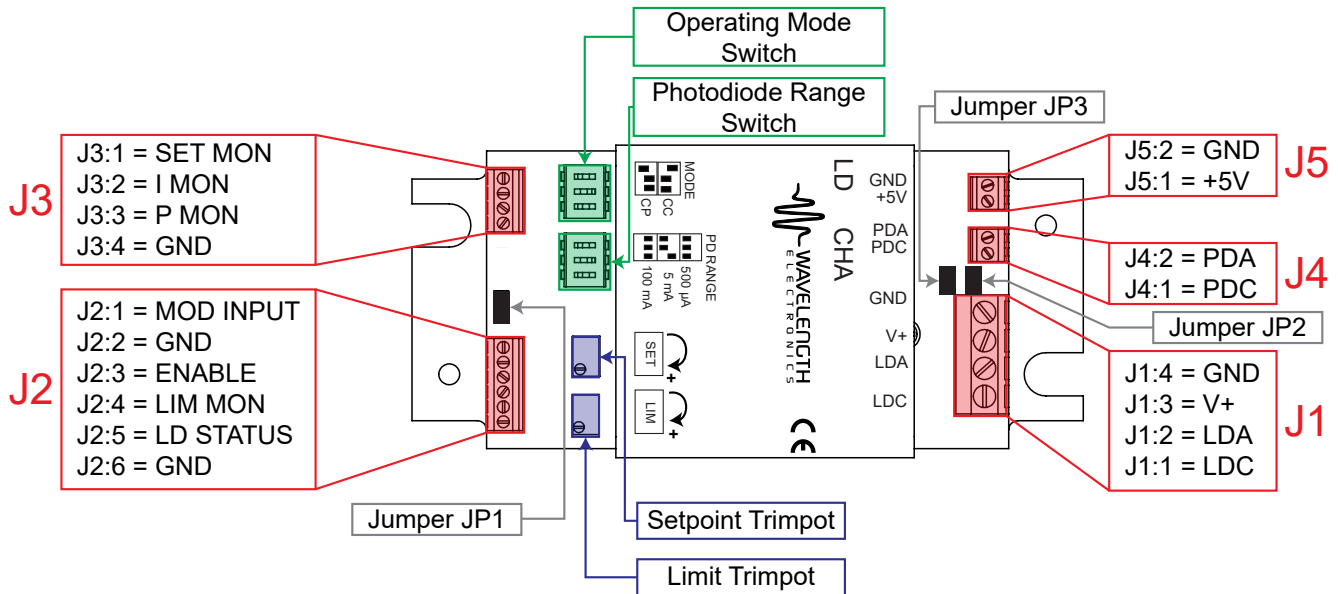

Figure 7. LDxCHA Driver Adjustments and Controls

SET THE CONTROL MODE

Choosing between Constant Current (CC) Mode and Constant Power (CP) Mode is done by using the upper set of DIP switches on the LDxCHA (as seen above in **Figure 7**). Constant Power mode operation requires a photodiode.



DO NOT SWITCH THE CONTROL MODE WHILE THE OUTPUT IS ENABLED AND DRIVING A LASER DIODE. THE LASER DIODE MAY BE DAMAGED OR DESTROYED.

To properly configure the LDxCHA for **Constant Current** operation, the left-most switch must be in the *upper* position, with the next two being in the *lower* position. The “ON” label and arrow (as seen on the switch itself) are shown for orientation. See **Figure 8** below.

To properly configure the LDxCHA for **Constant Power** operation, the left-most switch must be in the *lower* position, with the next two being in the *upper* position. The “ON” label and arrow (as seen on the switch itself) are shown for orientation. See **Figure 8** below.

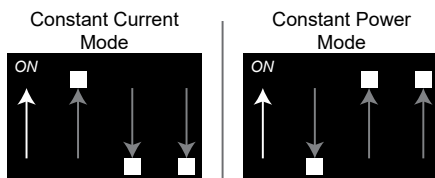

Figure 8. Proper MODE DIP switch orientation for Constant Current and Constant Power Mode.

SET THE PHOTODIODE RANGE – CONSTANT POWER MODE ONLY

In Constant Power Mode only, three photodiode feedback current ranges are available on the LDxCHA drivers. Choosing one of these photodiode ranges is done by using the lower set of DIP switches (as seen above in **Figure 7**) Reference the datasheet for your laser diode to find the nominal photodiode current, and set the PD RANGE switch as follows:

- 500 μA (down, down, down) = PD current 0 – 500 μA
- 5 mA (down, down, up) = PD current 500 μA – 5 mA
- 100 mA (up, up, up) = PD current 5 mA – 100 mA

Parentheses indicate switch positions, from left to right (see **Figure 9**).



DO NOT SWITCH THE PD RANGE WHILE THE OUTPUT IS ENABLED AND DRIVING A LASER DIODE. THE LASER DIODE MAY BE DAMAGED OR DESTROYED.

Note that the switches must be configured properly for minimum errors between the PD monitor (P MON) and the actual photodiode current.

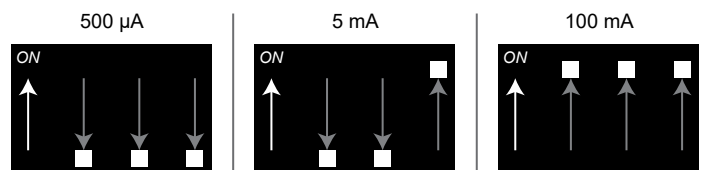

Figure 9. Proper PD RANGE DIP switch orientation for 500 μA, 5 mA, and 100 mA range.

## INSTALL OR REMOVE JUMPERS

There are three jumpers located on the circuit board, labeled JP1, JP2, and JP3 (see also **Figure 7**). They are all two position jumpers, so they are either installed, or uninstalled. The LDxCHA ships with all jumpers installed by the factory. Jumper functionality is described in **Table 3 on page 5**.

## DISABLE CURRENT

The LDxCHA allows for the user to set the current limit, output current setpoint, and modulation input *without* current flowing to the laser. In order to set these values with current disabled, ensure that the ENABLE pin (J2:3) is held high (voltage greater than 2 V), or leave this pin floating.

Once these values are set to the desired levels, current to the laser can be enabled by holding the ENABLE pin low (voltage less than 0.3 V).

## CALCULATE THE MONITOR VOLTAGES

### OUTPUT CURRENT LIMIT:

Refer to the datasheet for your laser to determine the maximum forward current, and calculate the current limit monitor voltage ( $V_{ILIMMON}$ ) using this equation and the transfer function found in **Table 2 on page 5**:

$$V_{ILIMMON} = I_{LIMIT} / \text{Transfer Function}$$

### OUTPUT CURRENT SETPOINT:

In Constant Current Mode, determine your desired current level and calculate the current setpoint monitor voltage ( $V_{ISETMON}$ ) using the transfer function found in **Table 2**:

$$V_{ISETMON} = I_{SET} / \text{Transfer Function}$$

*Note:* In Constant Power Mode, the output current setpoint is dependent on the photodiode response.

### CONSTANT CURRENT MODE:

If you are using the LDxCHA in Constant Current mode, calculate the monitor voltage for the drive current setpoint. Refer to the datasheet for your laser to determine the nominal forward current, and calculate the I MON voltage using the transfer function found in **Table 2**:

$$V_{IMON} = I_{LD} / \text{Transfer Function}$$

### CONSTANT POWER MODE:

If you are using the LDxCHA in Constant Power mode, calculate the photodiode current monitor voltage, P MON. Refer to the laser diode datasheet to determine the nominal photodiode current at the desired operating point. Choose the correct photodiode range configuration using the DIP switches for this photodiode range. Calculate the P MON voltage using the transfer function found in **Table 2**:

$$V_{PMON} = I_{PD} / \text{Transfer Function}$$

## APPLY POWER TO THE LDxCHA

In order to monitor these set values, the chosen power supply must be properly wired to the unit and turned on. See **Figure 5** and **Figure 6** for single and dual supply operation, respectively.

## SET THE CURRENT LIMIT

The current limit on the LDxCHA can be set *without* enabling current to the laser. In order to monitor the set current limit, connect the positive lead of the digital multimeter to the LIM MON pin (J2:4), and the negative lead to the GND terminal (J2:2). Use the transfer function listed in **Table 2** to determine the current limit proportional to the monitor voltage.

The onboard **LIM** trimpot is the only method of setting and adjusting the current limit. This is a 12-turn trimpot that increases with clockwise adjustments, and decreases with counter-clockwise adjustments. Prior to initial adjustment, turn the trimpot 12 full turns counter-clockwise to zero the trimpot.

Reference **Figure 7** for control locations on the LDxCHA:

- Disable output current, either by holding the ENABLE pin high, or allowing it to float.
- Switch on the +5 V power supply to the LDxCHA. (If dual-supply operation is being used, switch on both power supplies.)
- If the **LIM** trimpot has not previously been set to zero, do this by turning it at least 12 full turns counter-clockwise.
- Set the current limit by turning the **LIM** trimpot clockwise until the voltage displayed on the multimeter matches the value calculated for  $V_{ILIMMON}$  to the left.
- Switch off the power supply/supplies.

The LDxCHA controllers utilize a clipping current limit, ensuring that the output current will never exceed the limit set by the LIM trimpot. If the current approaches the limit that is set, the controller will clamp the output at or slightly below the limit, until the setpoint is backed down below the limit. Wavelength does not recommend operating in limit.

## ADJUST THE OUTPUT CURRENT SETPOINT – ONBOARD CONTROL

The output current setpoint on the LDxCHA can be set *without* enabling current to the laser. In order to monitor the output current setpoint, connect the positive lead of the digital multimeter to the SET MON pin (J3:1), and the negative lead to the GND terminal (J3:4). Use the transfer function listed in **Table 2** to determine the output current from the monitor voltage.

The onboard **SET** trimpot can be used to adjust the current setpoint either alone, or in conjunction with the MOD INPUT pin. If no modulation is necessary, install jumper JP1 to disable modulation input and minimize noise. In this scenario, the SET trimpot is the only method of setting the current setpoint. This is a 12-turn trimpot that increases with clockwise adjustments, and decreases with counter-clockwise adjustments. Prior to initial adjustment, turn the trimpot 12 full turns counter-clockwise to zero the trimpot.

Reference **Figure 7** for control locations on the LDxCHA:

- Disable output current, either by holding the ENABLE pin high, or allowing it to float.
- Switch on the +5 V power supply to the LDxCHA. (If dual-supply operation is being used, switch on both power supplies.)
- If the **SET** trimpot has not been previously set to zero, do this by turning at least 12 full turns counter-clockwise.
- *Constant Current Mode:* Set the current limit by turning the **SET** trimpot clockwise until the voltage displayed on the multimeter matches the value calculated for  $V_{\text{ISETMON}}$  on **page 12**.
- *Constant Power Mode:* Wavelength recommends leaving the **SET** trimpot at zero until current is enabled, and the power output can be monitored by the P MON pin (J3:3), or by an external power meter. See **page 14** for further instructions if operating in Constant Power Mode.
- Switch off the power supply/supplies.

## ADJUST THE OUTPUT CURRENT SETPOINT – MODULATION INPUT

The modulation input to the LDxCHA can be set *without* enabling current to the laser. To use MOD INPUT (pin J2:1) to adjust the output current, refer to Pin Descriptions on **page 4** for specifications. The modulation input signal can either sum with the onboard trimpot value, or provide the output current setpoint alone. If using the modulation input as the single source of setting the output current setpoint, the onboard SET trimpot must be set to zero. If the SET trimpot is not set to zero, the value of the modulation input will sum with the value of the onboard trimpot.

JP1 connects the modulation input to ground. In order to utilize modulation input to adjust the output current setpoint in either scenario, JP1 must be removed. Driving the external modulation input with this jumper installed will drive the input signal directly to ground, and may damage the signal source or function generator being used.

The modulation input signal can be used whether the driver is operating in Constant Current or Constant Power mode. Refer to **Table 2 on page 5** for the transfer function for Constant Current mode. For Constant Power mode, the LDxCHA's response to modulation input is dependent on the photodiode response. Wavelength recommends waiting to modulate until current is enabled, and the power output can be monitored by the P MON pin (J3:3), or by an external power meter. See **page 14** for further instructions if operating in Constant Power Mode.

Refer to the External Setpoint Circuit on **page 15** for an example analog input circuit. Other circuits, a DAC signal, or function generator may be used.

## COMBINING THE ONBOARD SETPOINT AND ANALOG INPUT

The MOD INPUT voltage signal on J2:1 sums with the onboard trimpot setpoint, provided that JP1 is removed. This configuration allows the driver to be configured so that the laser current or power modulates around a DC setpoint.

If the sum of the two signals causes the LDxCHA to attempt to drive the output current past the limit, the output will clip at the limit, providing limit current until the sum of the two signals drops below the set limit.

To avoid driving the current to the limit, first set the onboard trimpot to produce the Constant Current level. Then connect the modulation source to the MOD INPUT pin and slowly increase the modulation amplitude. Monitor the output current using the I MON pin, or by measuring the voltage across the test load. Do not monitor the voltage across a laser diode—measurement transients may damage the laser diode.

## ENABLE CURRENT

Once the operating parameters are set to the desired levels, current to the laser can be enabled by holding the ENABLE pin (J2:3) low (voltage less than 0.3 V).

## MONITOR THE ACTUAL OUTPUT CURRENT

Once output is enabled to the laser, the I MON pin (J3:2) can be used to monitor the actual output current that is reaching the laser.

To monitor the actual output current, connect the positive lead of the multimeter to the I MON pin, with the negative lead connected to GND (J3:4). Use the corresponding transfer function in **Table 2** to relate this monitor voltage to actual current.

## MONITOR THE PHOTODIODE CURRENT – CONSTANT POWER MODE

If the photodiode is connected to the LDxCHA and Constant Power Mode is chosen, the photodiode current can be monitored by connecting the positive lead of a multimeter to the P MON pin (J3:3), with the negative lead on the GND pin (J3:4), and reading the voltage. Refer to **Table 2 on page 5** for the transfer function to convert the P MON voltage to PD current. Ensure that the DIP switches are properly oriented for the photodiode range to minimize errors between monitor and actual photodiode currents.

Due to the fact that the output current setpoint cannot be accurately set prior to enabling output current in Constant Power Mode, Wavelength recommends starting with the SET trimpot at zero, then enabling output current and slowly increasing the setpoint until the desired power is reached.

## MONITOR THE MODULATION INPUT – CONSTANT POWER MODE

In Constant Power Mode, after enabling current, Wavelength recommends inputting a low depth of modulation signal, and slowly increasing the modulation towards the desired level, while monitoring the results.

## USING THE LD STATUS MONITOR PIN

Also on the Status Connections header (J2) is the LD STATUS monitor pin. This pin gives a high voltage (+5 V) when current is enabled to the laser, and a low voltage (0 V), when current is disabled.

To utilize the LD STATUS pin, connect the positive lead of the voltmeter to the LD STATUS pin (J2:5), and the negative lead to the GND terminal (J2:6).

## ENABLE LED

In addition the LD STATUS pin going high when current is enabled, the LDxCHA has an Enable LED, that will light when output current is enabled.

## ADDITIONAL TECHNICAL INFORMATION

This section includes useful technical information on these topics:

- External Setpoint Circuit
- Important Information on Grounding
- Cable Lengths and High Current
- Add Laser Diode Protection for Long Cables
- Additional Noise Filtering
- Product Variations
- Clipping Current Limit
- Slow Start Ramp
- Square Wave Response
- Power Supplies and Noise
- Maximizing The Resolution of the Photodiode Feedback Circuit
- Using the Enable Pin
- Choosing the Proper Heatsink
- Using the Modulation Input Pin with TTL Signals
- Safe Operating Area Calculation

### EXTERNAL SETPOINT CIRCUIT

An external trimpot circuit can be used to adjust the laser current setpoint; refer to **Figure 10**.

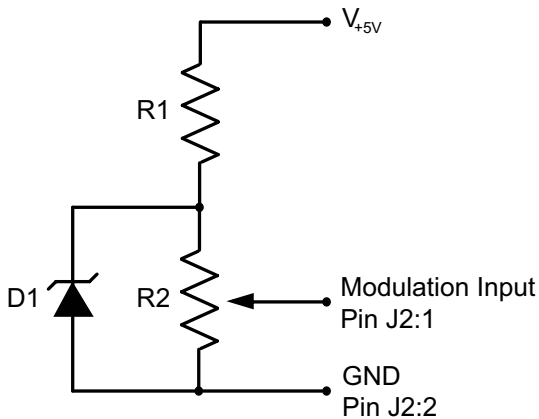

- $V_{+5V}$  = Supply voltage (5 to 30 V)
- D1 = Bandgap reference\* (ex: LM4040)
- R1 = 2.2 k $\Omega$ , 1 W resistor
- R2 = Trimpot, 10 k $\Omega$  to 100 k $\Omega$   
(Non-linear response due to mod. input impedance — see pg. 4 for value)

\* $V_{+5V}$  must be at least 1 volt greater than the voltage value of D1.

**Figure 10. Trimpot Circuit for Analog Input**

### IMPORTANT INFORMATION ON GROUNDING

Some laser diodes connect the laser anode or cathode to the case. In such cases special attention must be paid to grounding to ensure safe operation of the LDxCHA and laser.



IT IS CRITICAL THAT THE LDXCHA DRIVER IS PROPERLY GROUNDED. IF THE LDXCHA DRIVER IS USED WITH A WAVELENGTH ELECTRONICS TEMPERATURE CONTROLLER, YOU MAY NEED TO USE TWO SEPARATE POWER SUPPLIES THAT FLOAT INDEPENDENTLY OF EACH OTHER.

If the laser anode is connected to the laser case, it is possible that the anode will be connected to earth ground when the laser is installed in a benchtop mount or in your laser system. In situations where the laser diode is connected to the case, it is critical that the negative terminal of the power supply remain isolated from earth ground.

### CABLE LENGTHS AND HIGH CURRENT

The length and gauge of cable from the power supply or to the laser diode can impact performance. The resistance and inductance of the wire can reduce bandwidth or cause the voltage to the LDxCHA to droop.

### ADD LASER DIODE PROTECTION FOR LONG CABLES

With a cable longer than two feet, add a Schottky diode across the laser diode, see **Figure 11**.

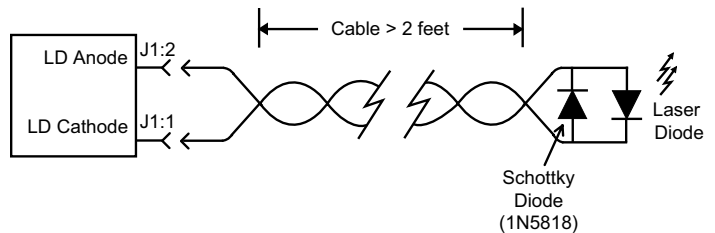

**Figure 11. Long Cable Laser Protection**

**ADDITIONAL NOISE FILTERING**

The LDxCHA drivers provide low-noise current to the laser diode, but in some cases additional filtering may be needed. Refer to **Figure 12** for a simple and effective filter.

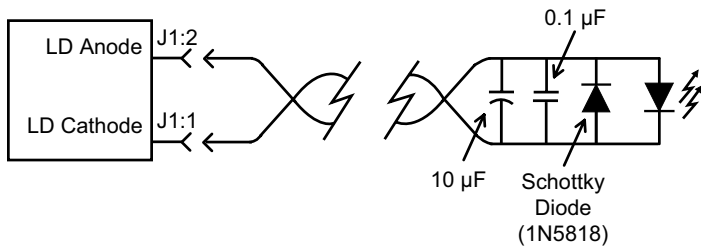

**Figure 12. LDxCHA Output Filter**

**PRODUCT VARIATIONS**

We design and manufacture our products in-house, and that gives us the unique ability to modify our drivers and controllers to suit your application. Our Product Variation service allows us to quickly and cost-effectively address your design requests, from prototype quantities to long-term high-volume manufacturing.

Examples of Product Variations include:

- Replacing the terminal blocks with pin headers, allowing for cables with sockets to be plugged in.
- Modifying the start delay time.
- Changing the photodiode range.
- Changing the photodiode transfer function.
- Changing the modulation transfer function.
- Changing the output current (from 50 mA up to a maximum of 15 A).

Contact Sales for information on how a Product Variation can be applied in your situation.

**CLIPPING CURRENT LIMIT**

The LDxCHA features a clipping current limit. This style of current limit means that the output current will never exceed the limit set by the user. If the current approaches the limit, the unit will force the output current to the value set by the limit. This feature is shown below in **Figure 13** and **Figure 14**, for a sine wave and square wave input, respectively.

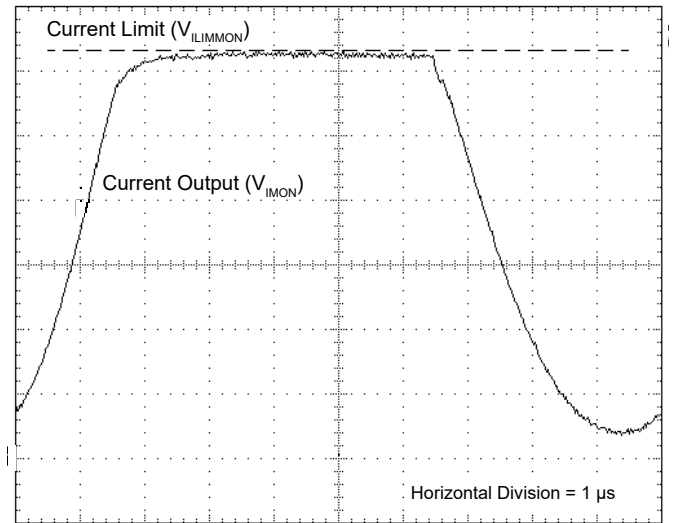

**Figure 13. Clipping Current Limit with a 100 kHz sine wave input at half current.**

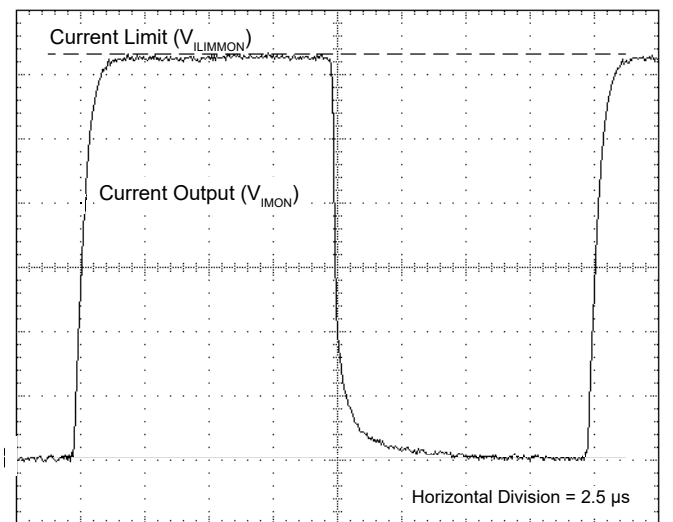
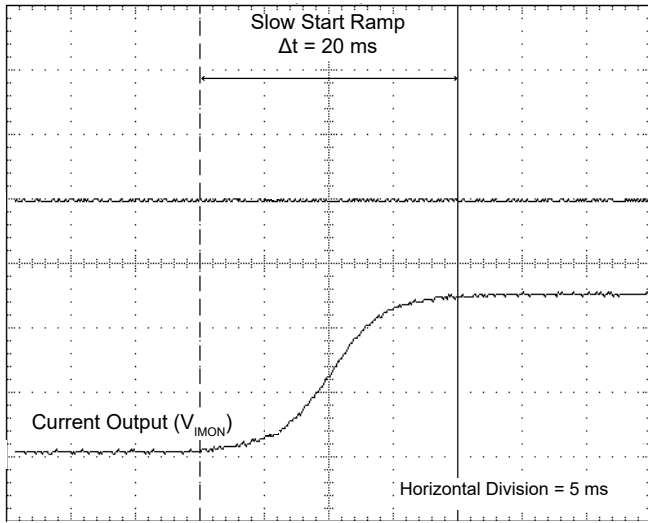

**Figure 14. Clipping Current Limit with a 50 kHz square wave input at half current.**



**SLOW START RAMP**

The slow start ramp on the LDxCHA is shown below in **Figure 15**.



**Figure 15. LDxCHA Slow Start Ramp**

**SQUARE WAVE RESPONSE**

The square wave response of the LDxCHA models varies, depending on output current. See **Figure 16** through **Figure 19** for results of a square wave input at full current.

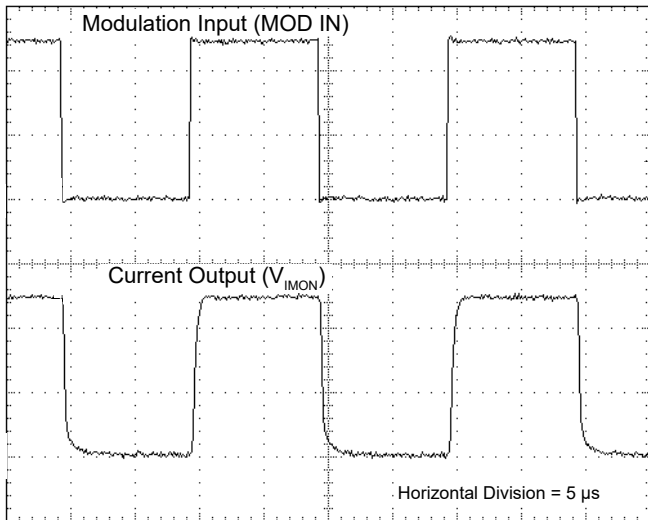

**Figure 16. LD2.5CHA response to a 50 kHz square wave input at current setpoint of 2.5 A.**

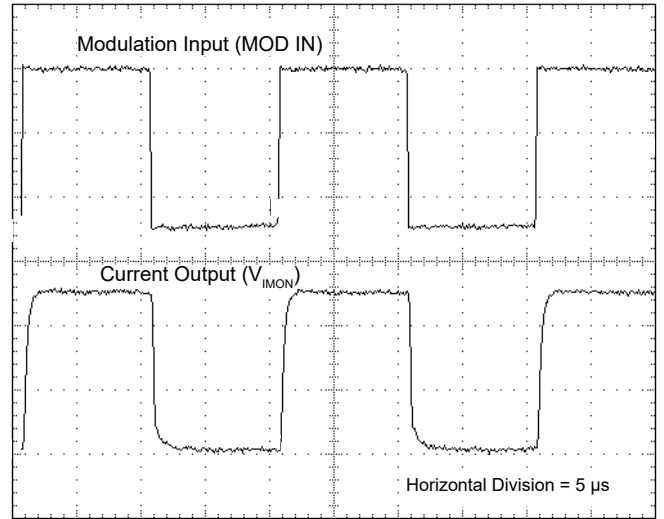

**Figure 17. LD5CHA response to a 50 kHz square wave input at current setpoint of 5 A.**

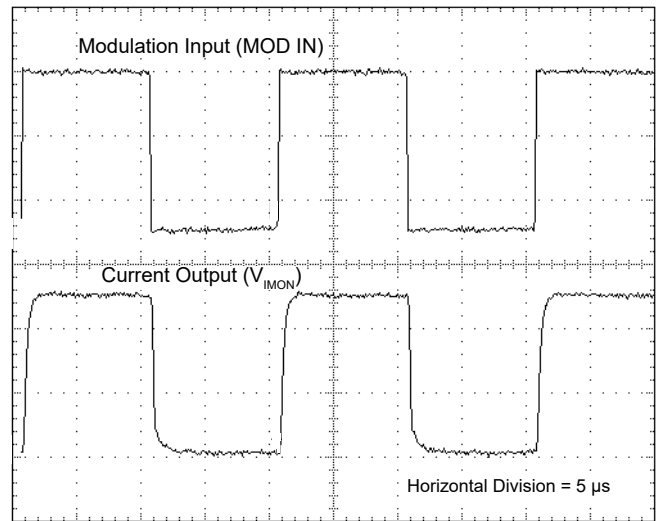

**Figure 18. LD10CHA response to a 50 kHz square wave input at current setpoint of 10 A.**

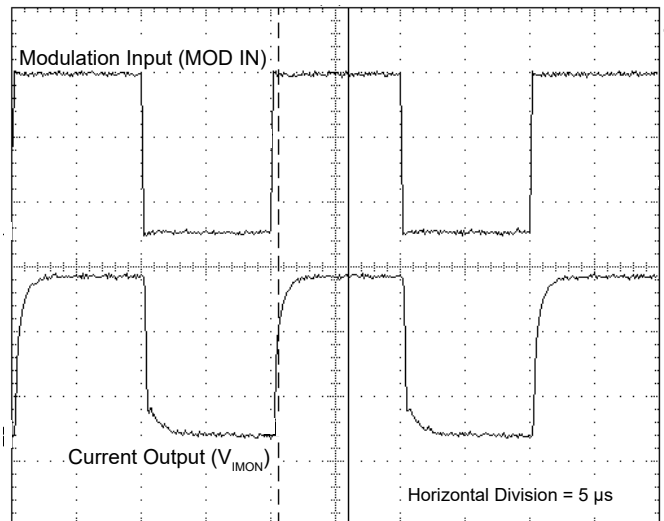

**Figure 19. LD15CHA response to a 50 kHz square wave input at current setpoint of 15 A.**

## POWER SUPPLIES AND NOISE

The LDxCHA drivers deliver stable current with low noise, but the chosen power supply will directly influence the noise performance of the driver.

We recommend using a regulated linear supply for the best noise performance, but depending on the application requirements, a switching power supply may be acceptable. Each case must be evaluated, because a switching power supply will affect noise, transient, and stability performance.

Wavelength offers several switching power supplies that may be appropriate.

MODEL	MAX VOLTAGE	MAX CURRENT
PWRPAK-13A-5V	5 V	13 A
PWRPAK-11A-12V	12 V	11 A
PWRPAK-16A-5V	5 V	16 A

**Table 4. Available power supplies.**

If the PWRPAK-16A-5V is used, there is a cable set available (WCB325) to simplify wiring.

For the ultimate in power supply performance at high currents, Wavelength recommends using a power supply with remote sensing leads. The remote sensing leads should connect to the V+ and GND pins on J1.

## MAXIMIZING THE RESOLUTION OF THE PHOTODIODE FEEDBACK CIRCUIT

The three options for the photodiode range feedback (set by the PD Range switches on the unit) should be chosen such that the current that the photodiode provides uses the most dynamic range possible.

For example, if the photodiode is providing 500  $\mu$ A of current, the 5 mA range choice would be poor, because the photodiode current to the LDxCHA is 10% of the full scale. On the other hand, the 500  $\mu$ A range choice would allow the LDxCHA circuitry to resolve that signal the best, with more sensitivity to variations in the photodiode current.

## USING THE ENABLE PIN

The ENABLE pin on the LDxCHA is designed to be TTL compatible. Thus, for current to be enabled, it must be held at a voltage less than 0.3 V. For current to be disabled, it must be held at a voltage greater than 2 V. Any values in between these limits are, by definition, undefined. As such, if this pin is held at a voltage of 1.5, there is no guarantee as to whether current is enabled or disabled.

## CHOOSING THE PROPER HEATSINK

Proper operation of the LDxCHA series of laser drivers requires heatsinking, to ensure that the unit stays within the Safe Operating Area (SOA). See the table below for the Wavelength recommended heatsink.

MODEL	RECOMMENDED HEATSINK
LD2.5CHA	MULTI-HTSK
LD5CHA	MULTI-HTSK
LD10CHA	MULTI-HTSK-HI
LD15CHA	MULTI-HTSK-HI*

**Table 5. Wavelength recommended heatsinks, by model.**

These recommendations are based on room-temperature ( $\sim 25^{\circ}\text{C}$ ) operation.

To ensure that the operating parameters used will allow the unit to stay within the SOA, use the online [SOA Calculator for Laser Diode Drivers](#) tool.

\* For single supply, 5 V operation of the LD15CHA, the MULTI-HTSK-HI with recommended airflow is adequate up to 15 A operation. However, when using a second power supply to allow higher voltage operation, the MULTI-HTSK-HI heatsink temperature can exceed  $50^{\circ}\text{C}$ . If operating the LD15CHA under these conditions, a user supplied higher capacity heatsink is required for safe operation.

## USING THE MODULATION INPUT PIN WITH TTL SIGNALS

The modulation input pin on the LDxCHA can be used with TTL signals, with a range of 0 to +5 V. This can be used as a method of pulsing the signal. Ensure that the current limit is properly set up prior to using TTL signals at the modulation input. When a high TTL signal is input to the modulation input pin, it will drive the LDxCHA's current output to the limit set by the user.

**SAFE OPERATING AREA CALCULATION**

The Safe Operating Area of the LDxCHA driver is determined by the amount of power that can be dissipated within the output stage of the driver. If that power limit is exceeded, permanent damage can result.



DO NOT OPERATE THE LDxCHA DRIVER OUTSIDE OF THE SAFE OPERATING AREA CURVE.

OPERATING THE LDxCHA DRIVER OUTSIDE OF THE SOA VOIDS THE WARRANTY.

Refer to the Wavelength Electronics website for the most up-to-date SOA calculator for our products. The online tool is fast and easy to use, and also takes into consideration operating temperature.

[www.teamwavelength.com/support/design-tools/soa-ld-calculator](http://www.teamwavelength.com/support/design-tools/soa-ld-calculator)

SOA charts are included in this datasheet for quick reference, however we recommend you use the online tools instead.

Follow these steps to determine if the driver will be operating within the SOA.

- Refer to the laser diode datasheet to find the maximum voltage ( $V_{MAX}$ ) and current ( $I_{MAX}$ ) specifications
- Calculate the voltage drop across the controller:

$$V_{DROP} = V_S - V_{MAX} \text{ (} V_S \text{ is the power supply voltage)}$$

- Mark  $V_{DROP}$  on the X-axis, and extend a line upward
- Mark  $I_{MAX}$  on the Y-axis, and extend a line to the right until it intersects the  $V_{DROP}$  line
- On the X-axis, mark value of  $V_S$
- Extend a diagonal line from  $V_S$  to the intersection of the  $V_{DROP}$  and  $I_{MAX}$  lines; this is the Load Line
- If the Load Line crosses the Safe Operating Area line at any point, the configuration is not safe

If the SOA Calculator indicates the LDxCHA will be outside of the Safe Operating Area, the system must be changed so that less power is dissipated within the driver. See Wavelength Electronics Application Note [AN-LDTC01: The Principle of the Safe Operating Area](#) for information on shifting the Load Line.

After changing any of the operating parameters, recalculate the SOA to make sure the driver will operate safely. If you have questions, or run into difficulties calculating the SOA, contact Wavelength Electronics for assistance.

For single supply, 5 V operation of the LD15CHA, the MULTI-HTSK-HI with recommended airflow (see **Figure 23**) is adequate up to 15 A operation. However, when using a second power supply to allow higher voltage operation, the MULTI-HTSK-HI heatsink temperature can exceed 50°C. If operating the LD15CHA under these conditions, a user supplied higher capacity heatsink is required for safe operation.

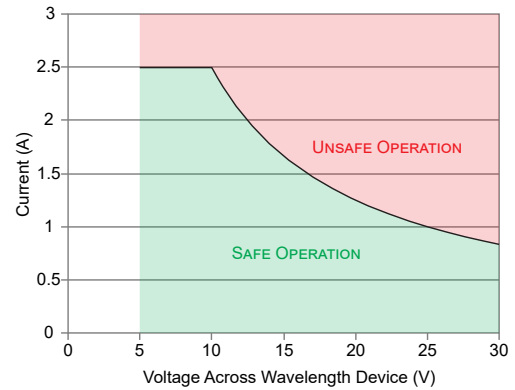

**Figure 20. SOA for LD2.5CHA with MULTI-HTSK, no airflow**

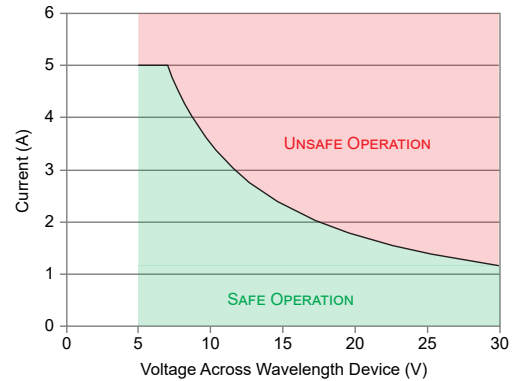

**Figure 21. SOA for LD5CHA with MULTI-HTSK and 5.5 CFM Airflow**

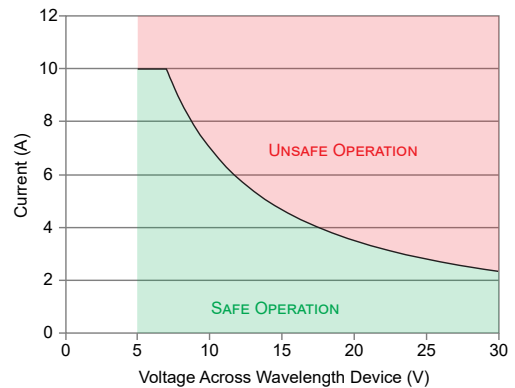

**Figure 22. SOA for LD10CHA with MULTI-HTSK-HI, 12 CFM airflow**

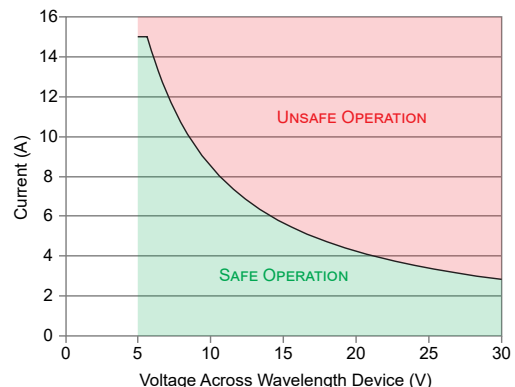

**Figure 23. SOA for LD15CHA with MULTI-HTSK-HI and 12 CFM Airflow**

## TROUBLESHOOTING

PROBLEM	POTENTIAL CAUSES	SOLUTIONS
Driver will not switch on	Improperly configured power supply	Carefully check the wiring diagram according to <b>page 10</b> .
Output will not enable	ENABLE pin not held low	Refer to the ENABLE pin specifications in <b>Table 1</b> and make sure this pin is held at a voltage less than 0.3 V.
	Over- or under-voltage protection has disabled output	The LDxCHA drivers have over- and under-voltage protection to protect the laser diode. Ensure that the voltage at the +5V pin (J5:1) is above 4 V, and below 6 V.
Laser output power too low in Constant Current mode	Laser current setpoint too low	Increase the setpoint either by adjusting the SET trimpot clockwise, or by increasing the signal voltage on MOD INPUT (pin J2:1).
	Laser current limit too low	Refer to <b>page 12</b> for instructions on setting the laser driver current limit.
	Laser driver is compliance limited	Check the laser diode specifications to determine the forward voltage ( $V_f$ ). Make sure that the LDxCHA is not compliance limited. Refer to the Electrical Specifications table on <b>page 6</b> . If the driver is compliance limited, V+ may need to be increased.  <b>Verify that the LDxCHA will be operating within the Safe Operating Area if V+ is increased.</b>
Laser does not reach desired output in Constant Power mode	Photodiode feedback current is out of range for the LDxCHA	Refer to the laser diode datasheet to determine the approximate photodiode (PD) current at the desired output power level. If the PD current exceeds the chosen LDxCHA photodiode current range, set the PD Range switch to a higher range; see <b>page 11</b> .
Modulation is not working	JP1 is not removed	The LDxCHA will not allow modulation signals to be passed through to the laser if JP1 is installed. To enable modulation, ensure that JP1 is removed.
Cannot zero the trimpots		The trimpots that are installed on the LDxCHA are 12-turn trimpots. This means that after 12 full turns counterclockwise, they will be set to zero, even though they will turn continuously.
Photodiode feedback is inaccurate	Improperly configured PD Range switch	If the switches for the PD Range are configured improperly, the LDxCHA will continue to operate, but the values that are returned will be less accurate. Ensure that these switches are oriented as shown in <b>Figure 9</b> for the desired range.
Transfer functions are inaccurate	Improperly configured CC/CP Mode switch	If the CC/CP Mode switches are improperly configured, this can lead to inaccuracies in the transfer functions. Ensure that these switches are oriented as shown in <b>Figure 8</b> for the desired operation mode.
Dual supplies are not working properly	JP2 is not removed	If dual supply operation is desired, ensure that JP2 is removed from the board. If JP2 is still installed, this can lead to issues with the power supplies.

## CABLING SPECIFICATIONS

### WCB308: POWER / LD CABLE (NOT INCLUDED)

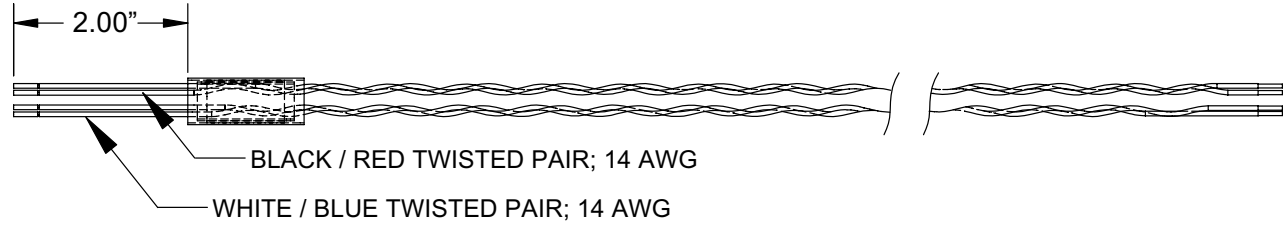

OVERALL LENGTH 24" ± 1" AFTER TWISTING

### WCB325: LDI5CHA SWITCHING POWER SUPPLY CABLES (NOT INCLUDED)

Black / White Twisted Pair  
14 AWG  
Overall length 24" ± 1"



BLACK = AC (Live)  
WHITE = AC (Neutral)

Black / Red Twisted Pair  
14 AWG  
Overall length 24" ± 1"



BLACK = GND (J1:4)  
RED = V+ (J1:3)

Black  
24 AWG  
Overall length 10"



BLACK = Safety Ground

# MECHANICAL SPECIFICATIONS

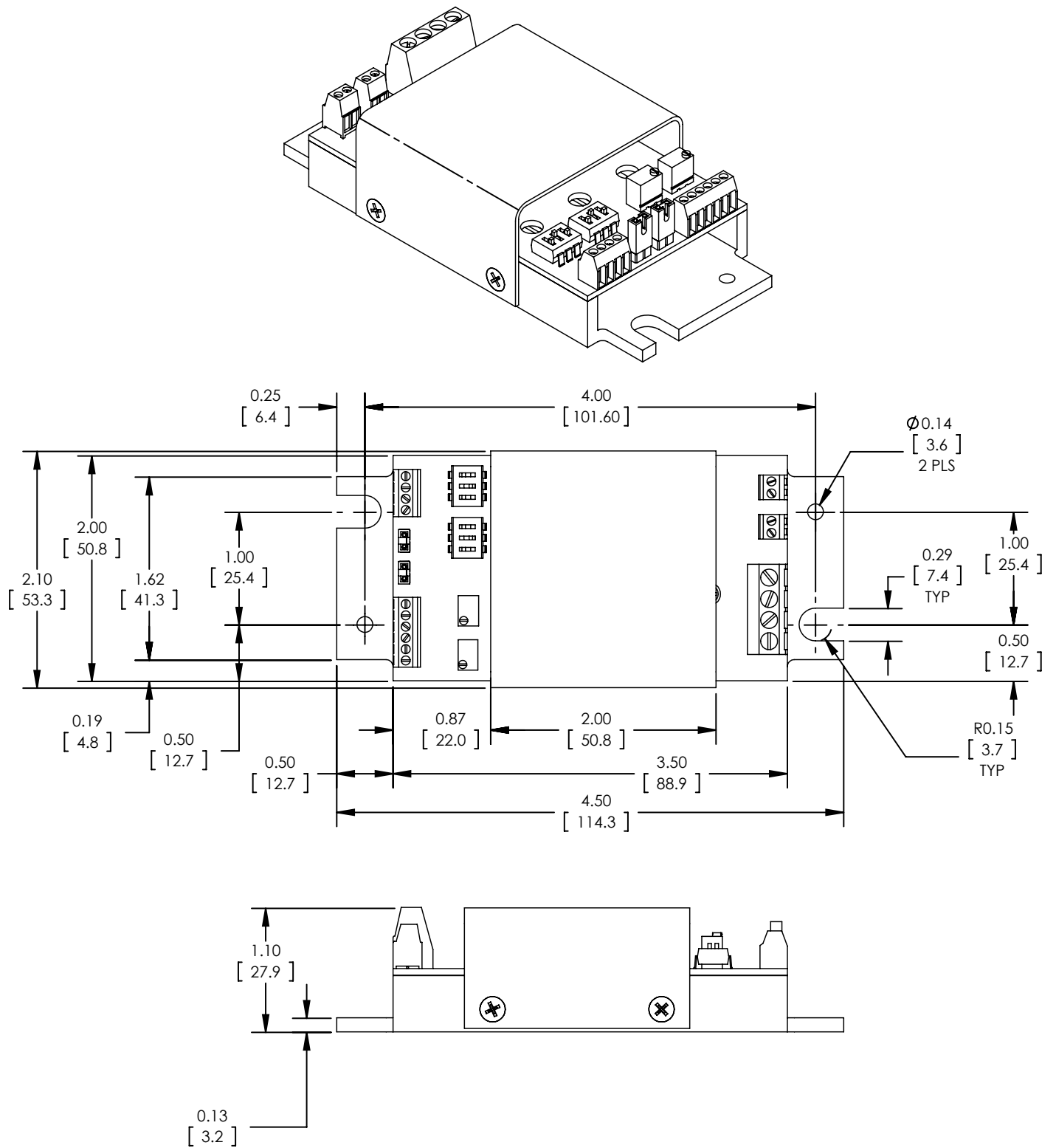

Figure 24. LDxCHA Driver Mechanical Dimensions

All Tolerances ±5%; units in inches [mm]

# CERTIFICATION AND WARRANTY

## CERTIFICATION

Wavelength Electronics, Inc. (Wavelength) certifies that this product met its published specifications at the time of shipment. Wavelength further certifies that its calibration measurements are traceable to the United States National Institute of Standards and Technology, to the extent allowed by that organization's calibration facilities, and to the calibration facilities of other International Standards Organization members.

## WARRANTY

This Wavelength product is warranted against defects in materials and workmanship for a period of one (1) year from date of shipment. During the warranty period, Wavelength will, at its option, either repair or replace products which prove to be defective.

## WARRANTY SERVICE

For warranty service or repair, this product must be returned to the factory. An RMA is required for products returned to Wavelength for warranty service. The Buyer shall prepay shipping charges to Wavelength and Wavelength shall pay shipping charges to return the product to the Buyer upon determination of defective materials or workmanship. However, the Buyer shall pay all shipping charges, duties, and taxes for products returned to Wavelength from another country.

## LIMITATIONS OF WARRANTY

The warranty shall not apply to defects resulting from improper use or misuse of the product or operation outside published specifications. No other warranty is expressed or implied. Wavelength specifically disclaims the implied warranties of merchantability and fitness for a particular purpose.

## EXCLUSIVE REMEDIES

The remedies provided herein are the Buyer's sole and exclusive remedies. Wavelength shall not be liable for any direct, indirect, special, incidental, or consequential damages, whether based on contract, tort, or any other legal theory.

## REVERSE ENGINEERING PROHIBITED

Buyer, End-User, or Third-Party Reseller are expressly prohibited from reverse engineering, decompiling, or disassembling this product.

## NOTICE

The information contained in this document is subject to change without notice. Wavelength will not be liable for errors contained herein or for incidental or consequential damages in connection with the furnishing, performance, or use of this material. No part of this document may be translated to another language without the prior written consent of Wavelength.

## SAFETY

There are no user-serviceable parts inside this product. Return the product to Wavelength Electronics for service and repair to ensure that safety features are maintained.

## LIFE SUPPORT POLICY

This important safety information applies to all Wavelength electrical and electronic products and accessories:

As a general policy, Wavelength Electronics, Inc. does not recommend the use of any of its products in life support applications where the failure or malfunction of the Wavelength product can be reasonably expected to cause failure of the life support device or to significantly affect its safety or effectiveness. Wavelength will not knowingly sell its products for use in such applications unless it receives written assurances satisfactory to Wavelength that the risks of injury or damage have been minimized, the customer assumes all such risks, and there is no product liability for Wavelength. Examples of devices considered to be life support devices are neonatal oxygen analyzers, nerve stimulators (for any use), auto-transfusion devices, blood pumps, defibrillators, arrhythmia detectors and alarms, pacemakers, hemodialysis systems, peritoneal dialysis systems, ventilators of all types, and infusion pumps as well as other devices designated as "critical" by the FDA. The above are representative examples only and are not intended to be conclusive or exclusive of any other life support device.

## REVISION HISTORY

DOCUMENT NUMBER: LD15CHA-00400

REV.	DATE	CHANGE
A	Jan. 2018	Initial Release
B	Feb. 2021	Updated for screw-in terminal blocks and wiring configurations



**WAVELENGTH**  
ELECTRONICS

51 Evergreen Drive  
Bozeman, Montana 59715

406-587-4910 (tel)  
406-587-4911 (fax)



Sales & Tech Support  
[sales@teamwavelength.com](mailto:sales@teamwavelength.com)  
[techsupport@teamwavelength.com](mailto:techsupport@teamwavelength.com)