

DATASHEET AND OPERATING GUIDE

FL500

Single 500 mA or Dual 250 mA Channel Laser Diode Driver



FLEXIBILITY YOU NEED

The FL500 Laser Diode Driver comes in a small SMT package that is reflow process compatible.

The FL500 is ideal for driving low power laser diodes. It operates from 3 to 12 V, so it is compatible with Li+ battery operation. This makes it practical for handheld devices.

It can be configured as two totally independent 250 mA drivers or a single 500 mA driver. It is compatible with Type A or Type B laser diodes.

FEATURES

- Small Package: 0.75" x 0.45" x 0.255"
- Low Cost
- Brownout Protection
- 12-Pin, SMT Package, Reflow Compatible
- Slow Start Laser Diode Protection
- Drive Up to 500 mA Output Current
- Can be configured as two 250 mA drivers
- Voltage Controlled Setpoint
- TTL Compatible Shutdown Pin
- Adjustable Current Limit on Evaluation Board
- Adjustable Current Range Output
- 500 kHz sinewave Constant Current Bandwidth (100 kHz square wave)

EASY INTEGRATION

The FL500 allows for quick and easy operation in Constant Current (CC) mode. For simple CC mode operation the only components that are required are a power supply, an analog control voltage, your laser and optional filtering circuitry.

For additional features, including current limit and photodiode feedback for Constant Power operation, use with the [FL591FL](#) driver board.

LEADING EDGE APPLICATIONS

The FL500 is commonly used in hand-held, portable, and space constrained applications. Small and light weight, the FL500 is ideal for airborne applications, spectroscopy systems, and the dual-channel output is perfect for sighting-and-detection applications.

CONTENTS

	PAGE
QUICK CONNECT GUIDE	2
PIN DESCRIPTION	4
ELECTRICAL SPECIFICATIONS	5
SAFETY INFORMATION	7
OPERATING INSTRUCTIONS	8
ADDITIONAL TECHNICAL INFORMATION	10
TROUBLESHOOTING	11
MECHANICAL SPECIFICATIONS	12
CERTIFICATION AND WARRANTY	13

ORDERING INFORMATION

PART NO	DESCRIPTION
FL500	500 mA Laser Diode Driver
FL591FL	500 mA Laser Diode Driver and Board

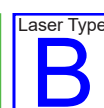

QUICK CONNECT GUIDE

- FL500 Pin Layout
- FL500 Connection Diagrams
- FL500 Test Loads
- FL500 Block Diagram

- page 2
- page 2
- page 3
- page 7



TO ENSURE SAFE OPERATION OF THE FL500 DRIVER, IT IS IMPERATIVE THAT YOU DETERMINE THAT THE UNIT WILL BE OPERATING WITHIN THE INTERNAL HEAT DISSIPATION SAFE OPERATING AREA (SOA).

Visit the Wavelength Electronics website for the most accurate, up-to-date, and easy to use SOA calculator:

<https://www.teamwavelength.com/support/design-tools/soa-ld-calculator/>

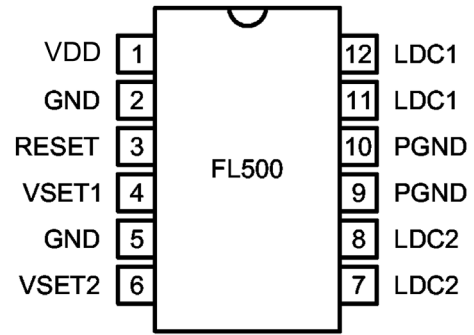

Figure 1. FL500 Top View Pin Layout

Figure 1 shows the top view Pin layout of the FL500 driver.

Figure 3 shows connection diagram for FL500 driver in single configuration.

Figure 2 shows connection diagram for FL500 driver in dual configuration.

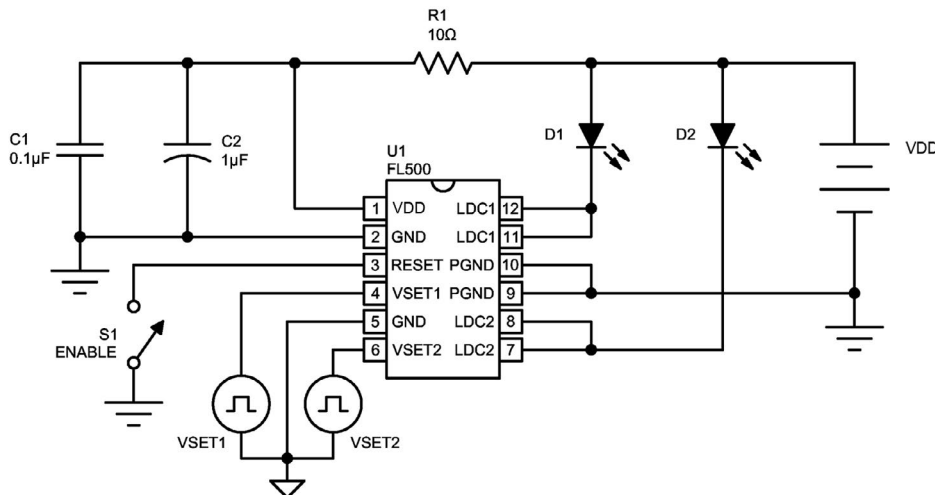

Figure 2. Dual 250 mA drivers configuration

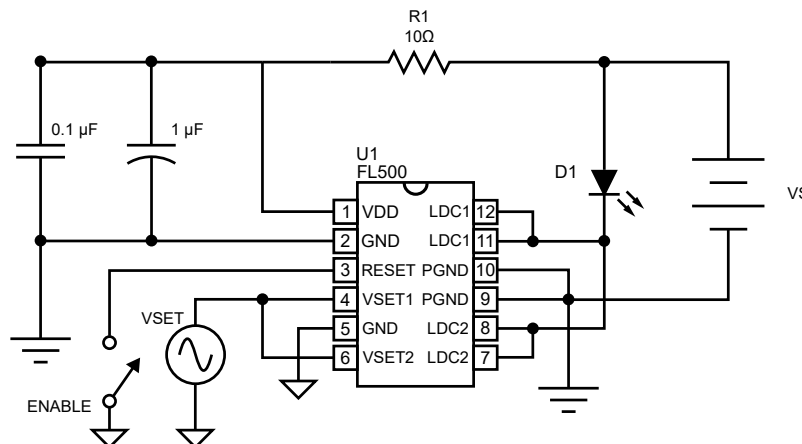

Figure 3. Single 500 mA driver configuration

QUICK CONNECT GUIDE, CONTINUED

The FL500 is compatible with Type A and Type B lasers, but will not drive Type C lasers: see **Figure 4**.

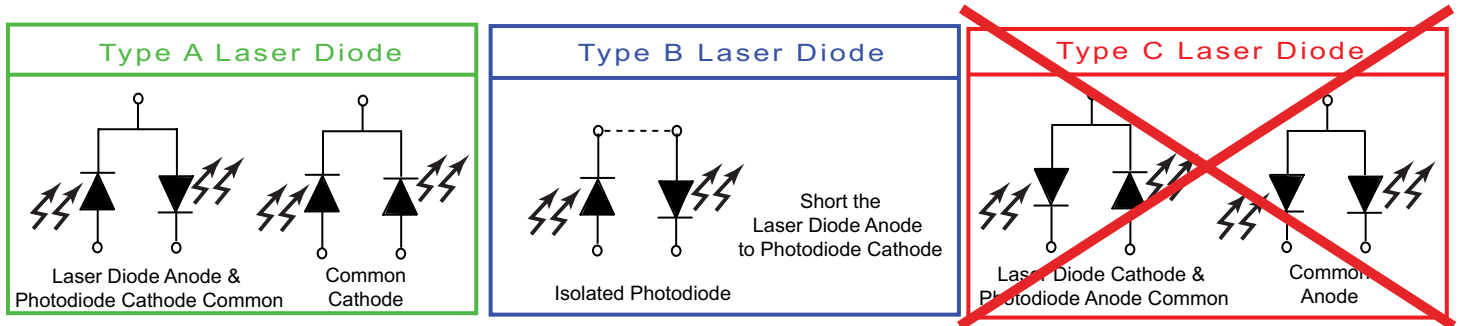

Figure 4. Laser Type Diagrams

LASER DRIVER TEST LOADS

Figure 5 shows a recommended simulated laser load for Type A and Type B lasers in Constant Current Mode. To determine the actual drive current, measure the voltage drop across the 1 Ω resistor. Do not insert an ammeter in series with the output circuit; doing so may cause instability in the control loop.

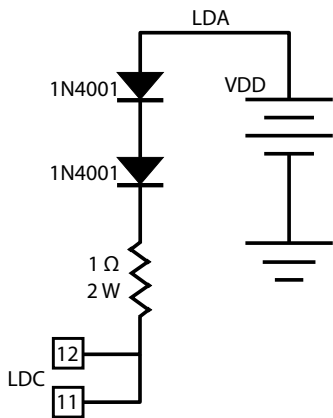

Figure 5. Laser Driver Test Load

PIN DESCRIPTION

Table 1. Pin Descriptions

PIN LABEL	PIN #	NAME	PIN DESCRIPTION
VDD	1	Control Electronics Power	Power supply input for the FL500's internal control electronics. Supply range input for this pin is +3 to +12 Volts DC. It is compatible with Li+ batteries.
GND	2	Control Electronics Ground	Return path for control electronics. Connect ground for V _{DD} power supply here. Do not use for high current ground return.
RESET	3	Enable / RESET Control	TTL compatible. LO = laser diode current on FLOAT or HI = laser diode current attenuated to ~10 μ A (~20 μ A if drivers are paralleled to produce 500 mA)
VSET1	4	Setpoint for LDC1 control	2 k Ω input impedance. 0 to 2 V range. There is no internal clamping, so higher voltage here will produce more current through the laser diode. Not recommended above 2 V.
GND	5	Ground for setpoint inputs	Low Current, Low Noise ground for use with VSET1 & VSET2.
VSET2	6	Setpoint for LDC2 control	2 k Ω input impedance. 0 to 2 V range. There is no internal clamping, so higher voltage here will produce more current through the laser diode. Not recommended above 2 V.
LDC2 LDC2	7 8	Laser Diode Cathode, Driver 2	Tie to laser diode cathode for individual drive operation (250 mA max). Tie to LDC1 for parallel operation up to 500 mA. Tie to pin 8 (also LDC2) if laser diode current exceeds 125 mA. Actual pin capacity is greater, but higher current produces offsets and higher noise.
PGND PGND	9 10	Power Ground for VS connection (VS powers laser diode)	Use for ground connection of VS power supply. Tie to pin 10 (also PGND) if laser diode current exceeds 125 mA.
LDC1 LDC1	11 12	Laser Diode Cathode, Driver 1	Tie to laser diode cathode for individual drive operation (250 mA max). Tie to LDC2 for parallel operation up to 500 mA. Tie to pin 12 (also LDC1) if laser diode current exceeds 125 mA. Actual pin capacity is greater, but higher current produces offsets and higher noise.

ELECTRICAL SPECIFICATIONS

PARAMETER	SYMBOL	MIN	TYP	MAX	UNIT
ABSOLUTE MAXIMUM RATINGS					
Supply Voltage (Voltage on Pin 1)	V_{DD}	+3		+12 *	Volts DC
Output Current (See SOA Chart)	I_{OUT}			500	mA
Power Dissipation, $T_{AMBIENT} = +25^{\circ}\text{C}$ [1]	P_{MAX}			2	Watts
Operating Temperature, case	T_{OPR}	- 40		+85	$^{\circ}\text{C}$
Storage Temperature	T_{STG}	- 55		+125	$^{\circ}\text{C}$
Weight	FL500		0.08		oz

PARAMETER	TEST CONDITIONS	MIN	TYP	MAX	UNIT
CONSTANT CURRENT CONTROL					
Short Term Stability, 1 hour	$T_{AMBIENT} = +25^{\circ}\text{C}$		35	40	ppm
Long Term Stability, 24 hours	$T_{AMBIENT} = +25^{\circ}\text{C}$	50		75	ppm
CONSTANT POWER CONTROL					
Short Term Stability, 1 hour [2]			0.019		%
Long Term Stability, 24 hours [2]			0.011		%
OUTPUT [3]					
Current, peak, see SOA chart	Per channel	245	250	252	mA
Current, peak, see SOA chart	Two channels operated in parallel	495	500	505	mA
Compliance Voltage, Laser Diode Load	Full Temperature Range, $I_{OUT} = 500\text{ mA}$	$V_{DD} - (0.5 \times V_{SET})$			V
Rise Time	$I_{OUT} = 500\text{ mA}$		300		nsec
Fall Time	$I_{OUT} = 500\text{ mA}$		300		nsec
Bandwidth (Constant Current)	Sine Wave		500		kHz
Bandwidth (Constant Current)	Square Wave		100		kHz
Delayed Start		100			msec
Slow Start ramp rate			15		mA / msec
Depth of Modulation	100 kHz sine wave		99		%
Transfer Function - V_{SET} to I_{OUT}	Two 250 mA drivers		0.125		A / V
Transfer Function - V_{SET} to I_{OUT}	One 500 mA driver		0.25		A / V
POWER SUPPLY					
Voltage, V_{DD}		3		12 *	V
Current, V_{DD} supply, quiescent		2.2	2.7	4.6	mA
VS, Maximum to LD Anode				20 *	V

*The FL591 Evaluation Board revision A or B limits the input voltage to 9 V. Revision C allows full range operation from +3 V to +12 V. Note [1]. Maximum Power Dissipation is 1 Watt per channel. When configured as one driver, maximum power dissipation is 2 W. Note [2]. Constant Power Control is available with the FL591FL diode driver and board as well as the FL500 with the LDTC0520/1020 combination boards.

Note [3]. Limit is fixed at 500 mA (250 mA per channel). The Evaluation Board circuitry adds a variable limit circuit.

ELECTRICAL SPECIFICATIONS CONTINUED

PARAMETER	TEST CONDITIONS	MIN	TYP	MAX	UNITS
INPUT					
Offset Voltage, initial, I_{MON}	Pin 2, $T_{AMBIENT} = +25^{\circ}C$, $V_{CM} = 0 V$		2		mV
Bias Current (based on input Res of op amp)	Pin 2, $T_{AMBIENT} = +25^{\circ}C$, $V_{CM} = 0 V$		10	15	nA
Common Mode Range	Pin 2, Full Temp. Range	0		V_{DD}	V
Common Mode Rejection, Setpoint	Full Temperature Range	-16	64		dB
Power Supply Rejection	Full Temperature Range	60			dB
THERMAL					
Heatspreader Temperature Rise	$T_{AMBIENT} = +25^{\circ}C$		43		$^{\circ}C / W$
Pin Solderability	Solder temp @260 $^{\circ}C$		10		Sec
NOISE					
Noise & Ripple (RMS)	$I_{OUT} = 100 mA$, 100 kHz bandwidth		3		μA
Leakage Current (when using the FL591 circuitry)	$V_{SET} = 0 V$		10*		μA
	$V_{SET} = 1 V$		100		μA
	$V_{SET} = 2 V$		150		μA

*For FL500 drivers built before June 2021 and before lot number 2119070, typical leakage current is 50 μA .

SAFETY INFORMATION

SAFE OPERATING AREA – DO NOT EXCEED INTERNAL POWER DISSIPATION LIMITS

Before attempting to operate the FL500 driver, it is imperative that you first determine that the unit will operate within the *Safe Operating Area* (SOA). Operating outside of the SOA may damage the laser and the FL500. Operating outside of the SOA will void the warranty.

To determine if the FL500 driver will be operating in the safe range in your application, consult the instructions for calculating the Safe Operating Area online:

www.teamwavelength.com/support/design-tools/soa-ld-calculator/

SOA charts are included in this datasheet for quick reference (page 11), but we recommend you use the online tools instead.



TO ENSURE SAFE OPERATION OF THE FL500 DRIVER, IT IS IMPERATIVE THAT YOU DETERMINE IF THE UNIT IS GOING TO BE OPERATING WITHIN THE INTERNAL HEAT DISSIPATION SAFE OPERATING AREA (SOA).

If you have any questions about the Safe Operating Area calculator, call the factory for free and prompt technical assistance.

PREVENT DAMAGE FROM ELECTROSTATIC DISCHARGE

Before proceeding, it is critical that you take precautions to prevent electrostatic discharge (ESD) damage to the driver and your laser. ESD damage can result from improper handling of sensitive electronics, and is easily preventable with simple precautions.

For more information regarding ESD, see Application Note [AN-LDTC06: Basics: Electrostatic Discharge \(ESD\)](#).

We recommend that you always observe ESD precautions when handling the FL500 driver and your laser diode.

THEORY OF OPERATION

The FL500 driver is a controlled current source: it delivers the current commanded by the setpoint. The current source continually monitors the actual output current, compares it to the setpoint, and adjusts the current if there is a difference between the two signals.

It may be useful to remember that you do not directly set the driver current setpoint; instead, you adjust a voltage signal that represents the output current. The voltage and output current are related by a transfer function that varies by driver capacity. The setpoint voltage is adjusted with an external input.

As current is driven through the load, there is a voltage drop across the load because of the impedance. As the current increases, the voltage drop may increase to the point that it reaches the Compliance Voltage limit of the current source. Once that occurs, the current source is no longer able to increase the current driven to the load even if you increase the setpoint.

Figure 6 shows the block diagram of the FL500.

The FL500 driver includes features that help protect your laser and make the driver more versatile in a wide array of applications: handheld devices, airborne applications, and spectroscopy systems.

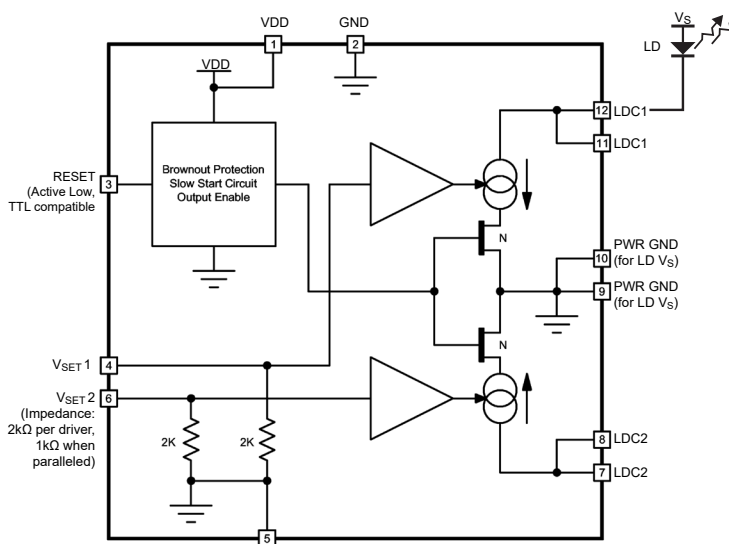

Figure 6. FL500 Block Diagram

OPERATING INSTRUCTIONS

The FL500 requires minimal external electronics. If you are using the driver on the benchtop or for prototyping your laser control system, we recommend purchasing the FL591FL Driver Board.

We recommend using a test load until you are familiar with operation of the driver. Refer to **page 3** for test load schematics.

NECESSARY EQUIPMENT

The following equipment is the minimum necessary to configure the FL500 for basic operation:

- FL500 Driver
- Digital Voltmeter, 4-½ digit resolution recommended
- Test load for configuring the driver [optional]
- Laser Diode
- Connecting wires
- Power Supply

STEP 1 - CHOOSE ONE OR TWO POWER SUPPLIES, VOLTAGES SOURCES

Configure the power supply to provide +3 to +12 VDC. Connect the positive terminal of the power supply (V_S) to Pin 1 and the negative terminal to Pins 9 and/or 10 (PGND) or Power Ground depending on the FL500 operation explained in the following steps below. Only ground V_S to Pin 2 if it is also grounded to Pins 9 or 10 (see **page 9**).

V_S powers the laser diode current source (or test load), and VDD powers the control electronics. Power the laser diode from VDD by connecting VDD where V_S is shown. For lower noise operation, separate VDD from V_S . V_S can be up to 20 V. At this level, however, too much power can be dissipated in the FL500 causing permanent damage. Calculate the power dissipated in the FL500 using the Safe Operating Area (SOA) Calculator online prior to using a V_S more than 2 V greater than the voltage dropped over the laser diode. **A maximum power dissipation of 1 W per source (2 W for paralleled operation) must not be exceeded.**

The minimum V_S is determined by the voltage drop across the laser diode and half the setpoint voltage. $V_{SMIN} = V_{LD} + VSET/2 + 25 \text{ mV}$ (across FET). Ground this power supply at Pins 9 & 10 (PGND). **Using Pin 2 could damage the FL500.**

Example V_{SMIN} :

$$V_{LD} = 1.2 \text{ V}$$

$$VSET = 1.5 \text{ V}$$

$$V_{SMIN} = 1.2 \text{ V} + (1.5 / 2) + 0.025 = 1.975$$

STEP 2 - CREATE A SETPOINT

Connect a voltage source to Pins 4 (VSET1) and/or Pins 6 (VSET2) and Pin 5 (GND) to create a setpoint for the current output. Check the specific configuration step below for more detailed instructions.

Pick the one of the following three wire configurations (step 3) that best fits your operation of the FL500.

STEP 3 - CONFIGURE THE WIRING

OPTION 1: OPERATE AS TWO INDEPENDENT DRIVERS

Connect the positive terminal of a power supply to Pin 4 (VSET1) and the positive terminal of another power supply to Pin 6 (VSET2). Connect both negative terminals to Pin 5 (GND). The power supplies do not need to be tied together. The transfer function for individual VSETs (1 & 2) is 0.125 A / V. The FL500 contains circuitry for two 250 mA drivers.

Connect one test load (laser diode) to Pins 11 & 12 (LDC1) and Pin 1 (VDD). Place the other test load on Pins 7 & 8 (LDC2) and Pin 1 (VDD). Make sure V_S is grounded at Pins 9 & 10 (PGND). Pin 2 (GND) will also be tied to this ground.

The RESET minimum current is 10 μA , and the leakage current is less than 1 mA. The FL500 has a known leakage current when disabled equal to the following magnitude:

$$I_{OUT(LEAK)} = \frac{V_{IN}}{20 \text{ k}\Omega}$$

This is well below 1 mA, and the usual leakage expected is 100 μA .

See **Figure 7** for typical operating schematic.

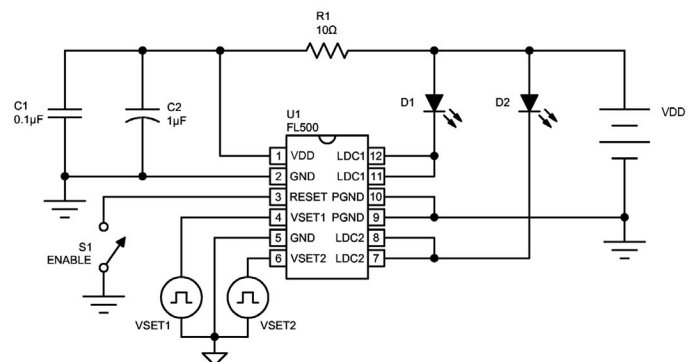

Figure 7. Single Supply Voltage Operating Two Independent Drivers

Leave Pins 6, 7, 8, and either 9 or 10 floating (or not connected to a power supply or ground) to limit the output current of the FL500 to 250 mA by using just one channel.

OPTION 2: OPERATE IN PARALLEL AS ONE DRIVER

Use only one power supply to power Pins 4 & 6 (VSET1 & VSET2) with ground at Pin 5 (GND). Wire the test load (laser diode) to Pins 7 & 8 (LDC2), Pins 11 & 12 (LDC1), and to Pin 1 (VDD). The FL500 contains circuitry for two 250 mA drivers. They can be run in parallel to deliver 500 mA to one laser diode (see **OPTION 1: Operate as two independent drivers** for single channel output current of 250 mA setup). Tie LDC1 & LDC2 together. VSET1 and VSET2 can be tied together or one can be used to set a DC bias while the other is used for an additive modulation signal. Only one V_S can be used. The transfer function for tied VSET(1 & 2) is 0.25 A / V.

The RESET minimum current is 20 μ A, and the leakage current is 2 mA. Note that if VSETs are tied together, input impedance becomes two 2 k Ω in parallel or 1 k Ω . The FL500 has a known leakage current when disabled equal to the following magnitude:

$$I_{OUT(LEAK)} = \frac{V_{IN}}{20 \text{ k}\Omega}$$

This is well below 1 mA, and usual leakage expected is 100 μ A.

See **Figure 8** for typical operating schematic.

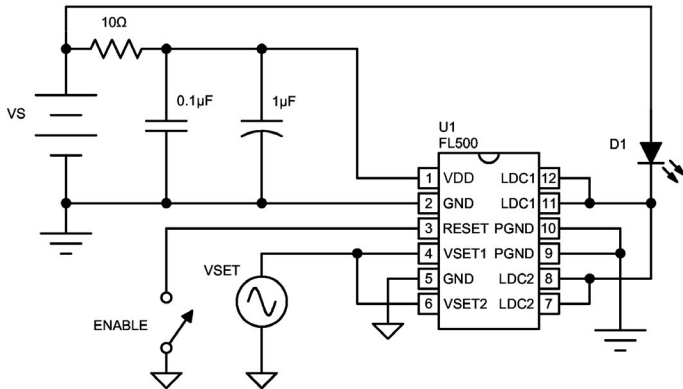

Figure 8. Parallel Operation as One Driver

OPTION 3: OPERATE MULTIPLE FL500S IN PARALLEL

Tie LDC1 & LDC2 (Pins 7 & 8, 11 & 12) on each FL500 together and wire the test load to these pins and Pin 1 (VDD). Tie PGND (Pins 9 & 10) together and use to ground V_S . Ground Pin 2 as well. Tie each Pin 3 (RESET) together and ground to enable current to the load. Tie each VSETs (Pins 4 & 6) together and wire the other power supply to these pins with ground at Pins 5 (both grounded).

Multiple FL500s can be used in parallel for 1 A, 1.5 A, etc. operation: Note input impedance on VSET drops. For two FL500s configured for 500 mA each and used in parallel, the input impedance drops to 500 Ω .

See **Figure 9** for typical operating schematic.

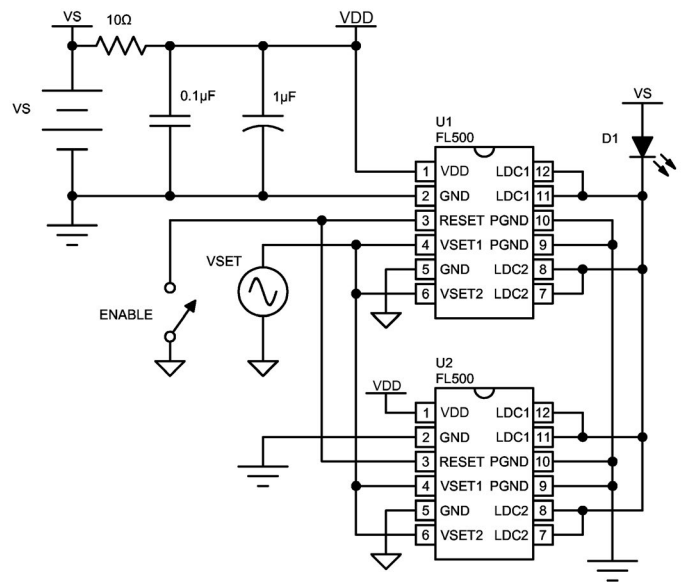

Figure 9. Multiple Units in Parallel Operation

STEP 4 - RESET / ENABLE FUNCTION [PIN3]

Ground Pin 3 to enable output current to the laser diode. This control pin is common to both sources. When active, this pin attenuates the output current amplitude to near zero (~10 μ A when configured for 250 mA max and ~20 μ A if drivers are paralleled to produce 500 mA). Current still flows through the laser diode. The pin is active LO.

LO = LD current flowing to setpoint.
 FLOAT or HI = LD current attenuated.

The input is TTL compatible.

BROWN OUT PROTECTION

If V_{DD} drops below 2.7 V, the RESET circuit is triggered immediately (on the order of 100 μ sec), reducing current through the laser diode to attenuated levels (~10 μ A).

DELAYED / SLOW START

Once power is applied, current at the attenuated level will flow (~10 μ A when configured for 250 mA max). After 100 msec, current will rise to the level dictated by the setpoint voltage at the rate of about 15 mA / msec. This delay ensures that all control electronics are functioning before significant current flows to the laser diode. The delay time is set with internal components. [It can be increased - please request a modification through Sales.] Refer to **Figure 10** for a typical sequence.

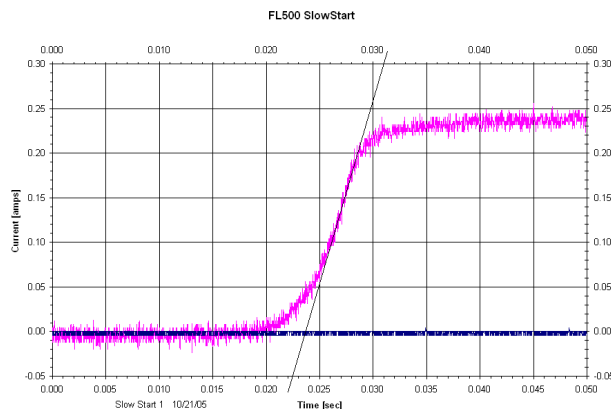
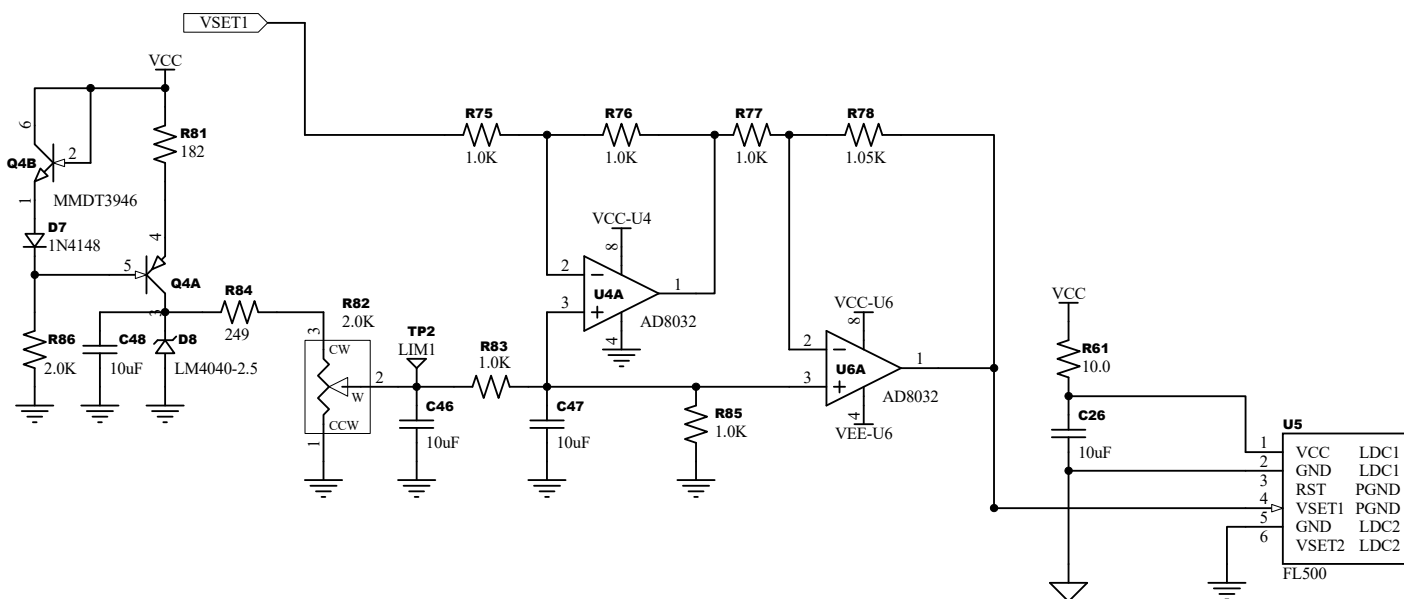

Figure 10. Typical Delayed / Slow Start Response

CURRENT LIMIT

To set current limits, use the circuit below from the FL591 schematic. To set two current limits (one for each individual driver), use the same circuit to also connect to VSET2.



CONSTANT POWER MODE

To operate in Constant Power mode with photodiode feedback, use the circuit below from the FL591 schematic.

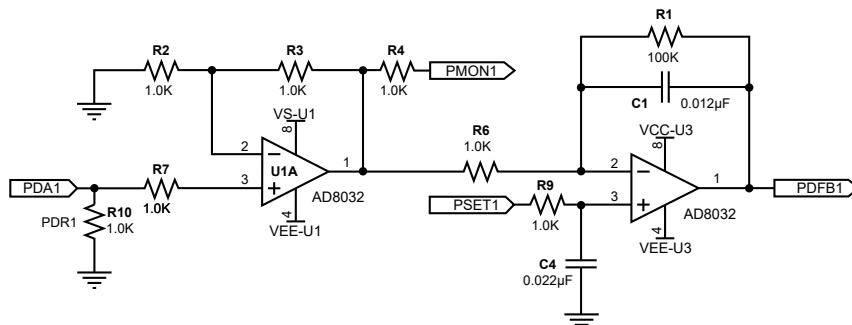

ADDITIONAL TECHNICAL INFORMATION

SAFE OPERATING AREA

The Safe Operating Area of the FL500 laser diode driver is determined by the amount of power that can be dissipated within the output stage of the driver. If that power limit is exceeded permanent damage can result.



DO NOT EXCEED THE SAFE OPERATING AREA (SOA). EXCEEDING THE SOA VOIDS THE WARRANTY.

Refer to the Wavelength Electronics website for the most up-to-date SOA calculator for our products. The online tool is fast and easy to use, and also takes into consideration operating temperature.

www.teamwavelength.com/support/design-tools/soa-ld-calculator/

SOA charts are included in this datasheet for quick reference, however we recommend you use the online tools instead.

An example SOA calculation for the FL500 for 1 W, 250 mA for independent channels operation is shown in **Figure 11** where:

$V_S = 5$ Volts (Point C) $V_{LOAD} = 2.5$ Volts
 $I_{LOAD} = 100$ mA (Point B) $V_{DROP} = 5 - 2.5 = 2.5$ Volts (Point A)

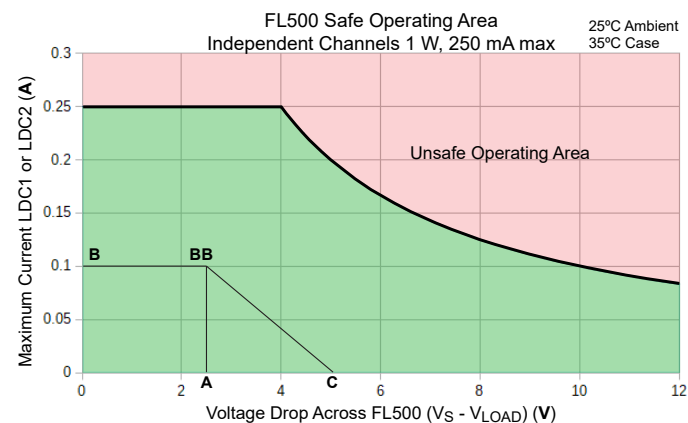

Figure 11. FL500 Independent Channels SOA

Follow these steps to determine if the driver will be operating within the SOA.

- Refer to the laser datasheet to find the maximum voltage (V_{LOAD}) and current (I_{LOAD}) specifications
- Calculate the voltage drop across the driver: $V_{DROP} = V_S - V_{LOAD}$ (V_S is the power supply voltage)
- Mark V_{DROP} on the X-axis, and extend a line upward
- Mark I_{LOAD} on the Y-axis, and extend a line (Line BB) to the right until it intersects the V_{DROP} line
- On the X-axis, mark the value of V_S
- Extend a diagonal line from V_+ to the intersection of the V_{DROP} and I_{LOAD} lines; this is the Load Line
- If the Load Line crosses the Safe Operating Area line at any point, the configuration is not safe

If the SOA Calculator indicates the FL500 will be outside of the Safe Operating Area, the system must be changed so that less power is dissipated within the driver. See Wavelength Electronics Application Note [AN-LDTC01: The Principle of the Safe Operating Area](#) for information on shifting the Load Line.

An example SOA calculation for the FL500 for 2 W, 500 mA for parallel channels operation is shown in **Figure 12** where:

$V_S = 3$ Volts (Point C) $V_{LOAD} = 2$ Volts
 $I_{LOAD} = 400$ mA (Point B) $V_{DROP} = 3 - 2 = 1$ Volts (Point A)

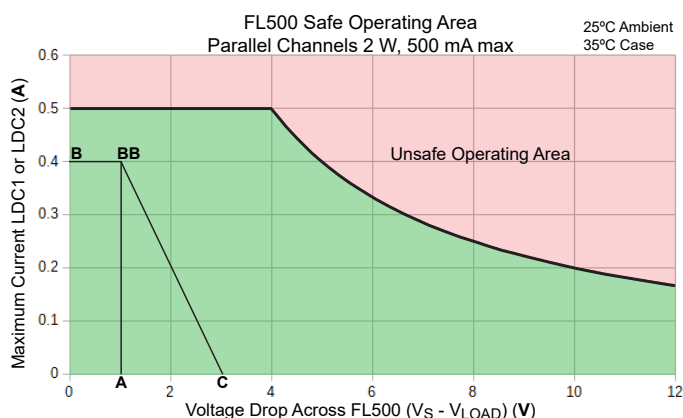

Figure 12. FL500 Parallel Channels SOA

TROUBLESHOOTING

PROBLEM	POTENTIAL CAUSES	SOLUTIONS
Driver will not switch on	Improperly configured power supply	Carefully check the wiring diagram according to page 8 and page 9 . If operating the FL500 with the Evaluation Board, see the FL591FL Datasheet for details regarding power supply.
Output will not enable	ENABLE Pin not held low	Refer to the RESET/ENABLE control (Pin 3) in Table 1 on page 4 .
Laser output power too low in Constant Current mode	Laser voltage setpoint too low	Increase the setpoint by increasing the voltage at Pin 4 & 6 (VSET1 & VSET2). VSET1 & VSET2 may be tied together if operating in parallel.
	Laser current limit too low	The current limit is fixed at 500 mA (250 mA per channel). The Evaluation Board circuitry adds a variable limit current.
	Laser driver is compliance limited	Check the laser diode specifications to determine the forward voltage (V_F). Make sure that the FL500 is not compliance limited. Refer to the Electrical Specifications table on page 5 . If the driver is compliance limited, VDD may need to be increased. Verify that the FL500 will be operating within the Safe Operating Area if VDD is increased.
Driver will not operate in Constant Power mode	Not available with the standalone driver	Constant Power Control is available when the FL500 is used with the FL591 (Evaluation Board) as well as the LDTC0520/1020 combination modules.
Transfer functions are inaccurate	Operating as two 250 mA drivers instead of one 500 mA driver or reverse	The Transfer Function for operation as two 250 mA drivers is 0.125 A / V. The Transfer Function for operation as one 500 mA driver is 0.25 A / V. This is seen in the Electrical Specifications table on page 5 .

MECHANICAL SPECIFICATIONS

FL500 IS REFLOW PROCESS COMPATIBLE.

All dimensions are $\pm 5\%$

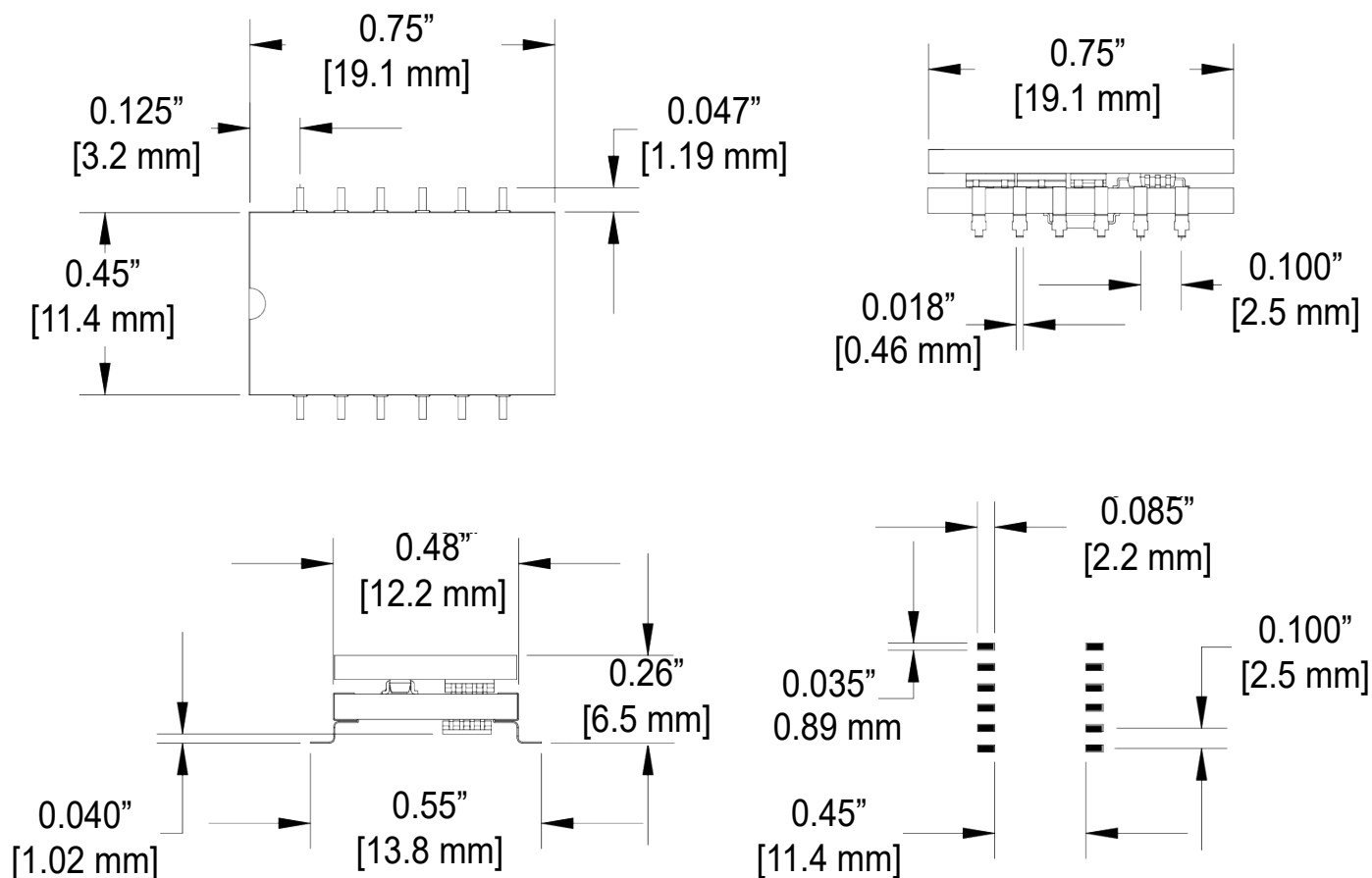

PCB FOOTPRINT

CERTIFICATION AND WARRANTY

CERTIFICATION

Wavelength Electronics, Inc. (Wavelength) certifies that this product met its published specifications at the time of shipment. Wavelength further certifies that its calibration measurements are traceable to the United States National Institute of Standards and Technology, to the extent allowed by that organization's calibration facilities, and to the calibration facilities of other International Standards Organization members.

WARRANTY

This Wavelength product is warranted against defects in materials and workmanship for a period of one (1) year from date of shipment. During the warranty period, Wavelength will, at its option, either repair or replace products which prove to be defective.

WARRANTY SERVICE

For warranty service or repair, this product must be returned to the factory. An RMA is required for products returned to Wavelength for warranty service. The Buyer shall prepay shipping charges to Wavelength and Wavelength shall pay shipping charges to return the product to the Buyer upon determination of defective materials or workmanship. However, the Buyer shall pay all shipping charges, duties, and taxes for products returned to Wavelength from another country.

LIMITATIONS OF WARRANTY

The warranty shall not apply to defects resulting from improper use or misuse of the product or operation outside published specifications. No other warranty is expressed or implied. Wavelength specifically disclaims the implied warranties of merchantability and fitness for a particular purpose.

EXCLUSIVE REMEDIES

The remedies provided herein are the Buyer's sole and exclusive remedies. Wavelength shall not be liable for any direct, indirect, special, incidental, or consequential damages, whether based on contract, tort, or any other legal theory.

REVERSE ENGINEERING PROHIBITED

Buyer, End-User, or Third-Party Reseller are expressly prohibited from reverse engineering, decompiling, or disassembling this product.

NOTICE

The information contained in this document is subject to change without notice. Wavelength will not be liable for errors contained herein or for incidental or consequential damages in connection with the furnishing, performance, or use of this material. No part of this document may be translated to another language without the prior written consent of Wavelength.

SAFETY

There are no user-serviceable parts inside this product. Return the product to Wavelength Electronics for service and repair to ensure that safety features are maintained.

LIFE SUPPORT POLICY

This important safety information applies to all Wavelength electrical and electronic products and accessories:

As a general policy, Wavelength Electronics, Inc. does not recommend the use of any of its products in life support applications where the failure or malfunction of the Wavelength product can be reasonably expected to cause failure of the life support device or to significantly affect its safety or effectiveness. Wavelength will not knowingly sell its products for use in such applications unless it receives written assurances satisfactory to Wavelength that the risks of injury or damage have been minimized, the customer assumes all such risks, and there is no product liability for Wavelength. Examples of devices considered to be life support devices are neonatal oxygen analyzers, nerve stimulators (for any use), auto-transfusion devices, blood pumps, defibrillators, arrhythmia detectors and alarms, pacemakers, hemodialysis systems, peritoneal dialysis systems, ventilators of all types, and infusion pumps as well as other devices designated as "critical" by the FDA. The above are representative examples only and are not intended to be conclusive or exclusive of any other life support device.

REVISION HISTORY

DOCUMENT NUMBER: FL500-00400

REV.	DATE	CHANGE
F	Feb. 2009	Updated to include FL500 Reflow Oven compatibility
G	Sept. 2009	Updated to reflect RoHS Status
H	June 2013	Updated Noise & Ripple specifications
I	Mar. 2014	Clarified reflow compatibility
J	Dec. 2014	Updated to fully reflow compatible
K	Nov. 2015	Updated leakage current specification
L	Oct. 2020	Updated to new format, added current limit and PD feedback



**WAVELENGTH
ELECTRONICS**

51 Evergreen Drive
Bozeman, Montana 59715



406-587-4910 (tel)
406-587-4911 (fax)
Sales & Tech Support

sales@teamwavelength.com

techsupport@teamwavelength.com