

PSH 10/2

2-Axis Mirror Tilting Platform



Tilting axes in perpendicular orientation



*Tilting range ± 4 mrad
 ± 8 mrad optical*



Sub- μ rad resolution

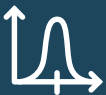

3.5 kHz resonant frequency



The PSH 10/2 mirror positioning stage consists of 4 piezoelectric actuators – 2 stacks for each axis, controlled in conjunction with each other. These actuators provide tilt to the top plate on 2 rectangular axes. The construction is temperature compensated so that changes of the surrounding temperature do not affect the tilting angle. This tilting positioning stage is designed for plus-minus tilting. Mirror mounts are preloaded, thus they are well suited for dynamic applications.

The high resonant frequency of this mirror positioning systems also allows for excellent dynamic operation. An integrated strain gauge measurement system is available for closed-loop applications.

Variants:

- With strain gauge (SG)

Recommended Controller:

NV200/D Net

Applications

- Beam steering
- Scanning processes
- Precise adjustment of optical components
- Beam stabilization

PSH 10/2

Technical Data

	<i>Unit</i>	<i>PSH 10/2</i>		<i>PSH 10/2 SG</i>	
Part #	-	K-110-00		K-110-01	
Sensor	-	-		Strain Gauge	
Axes	-	X	Y	X	Y
Max. tilt per axis in open-loop (±10%)	mrad			±4	
Max. tilt per axis in closed-loop (±0.2%)		-		±4	
Typ. resolution open-loop*	μrad			0.02	
Typ. resolution closed-loop*		-		0.2	
Resonant frequency incl. mirror 5g	Hz			3500	
Stiffness in z	Nm/mrad			0.5	
Capacity per axis (±20%)**	μF			3.4	
Voltage	V			-20 ... 130	
Material	-	Stainless Steel/ Aluminum		Stainless Steel/ Aluminum	
Connector	-	ODU 3pin		LEMO 05.304	
Cable length	m	1		1.2	
Dimensions (LxWxH)	mm	22x22x47.5		22x22x53	
Mass	g	52		95	

* the resolution is only limited by the noise of the power amplifier and metrology.

** typical value for small electrical field strength

PSH 10/2

Part Drawing

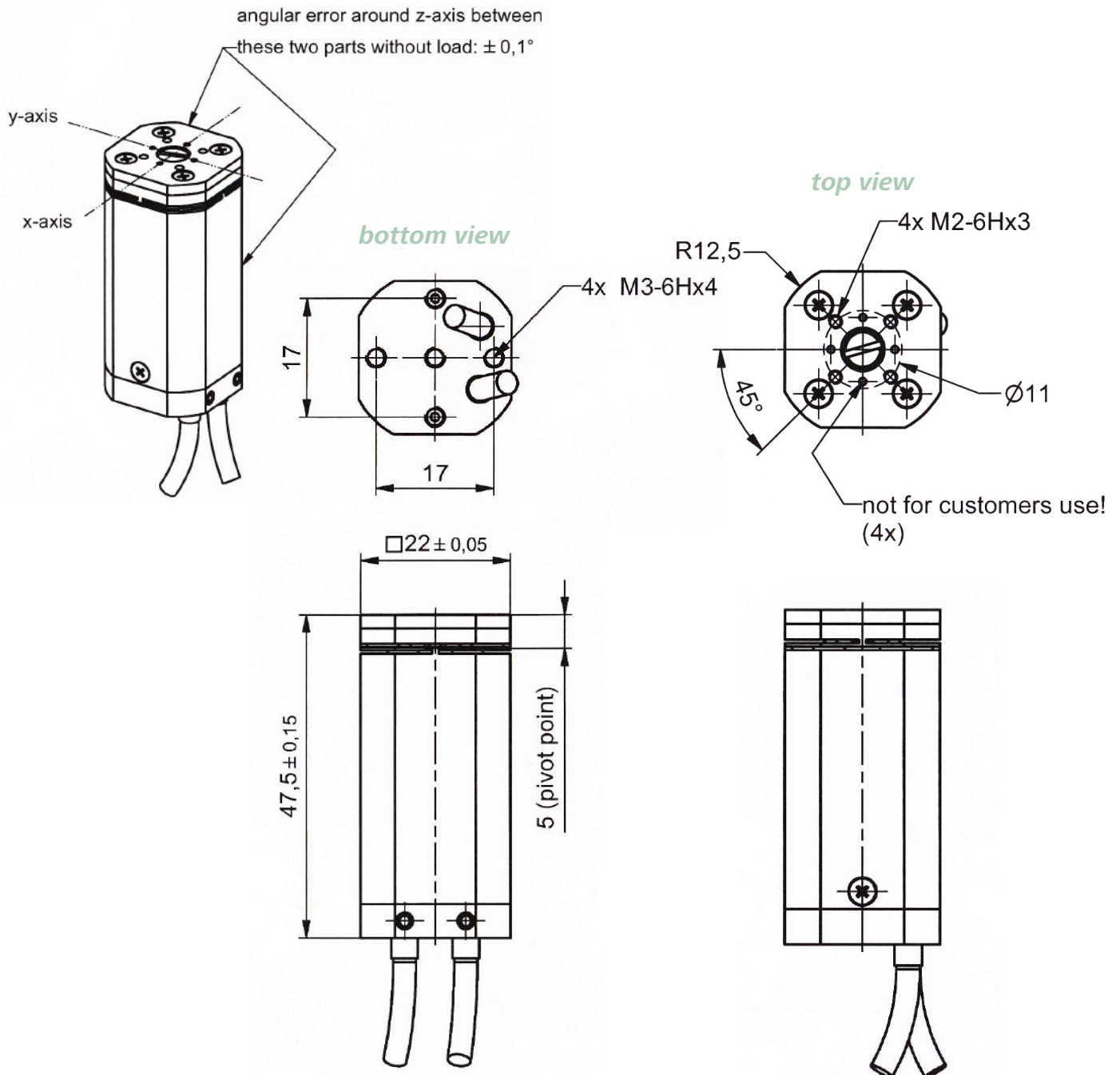

PSH 10/2 SG

Part Drawing

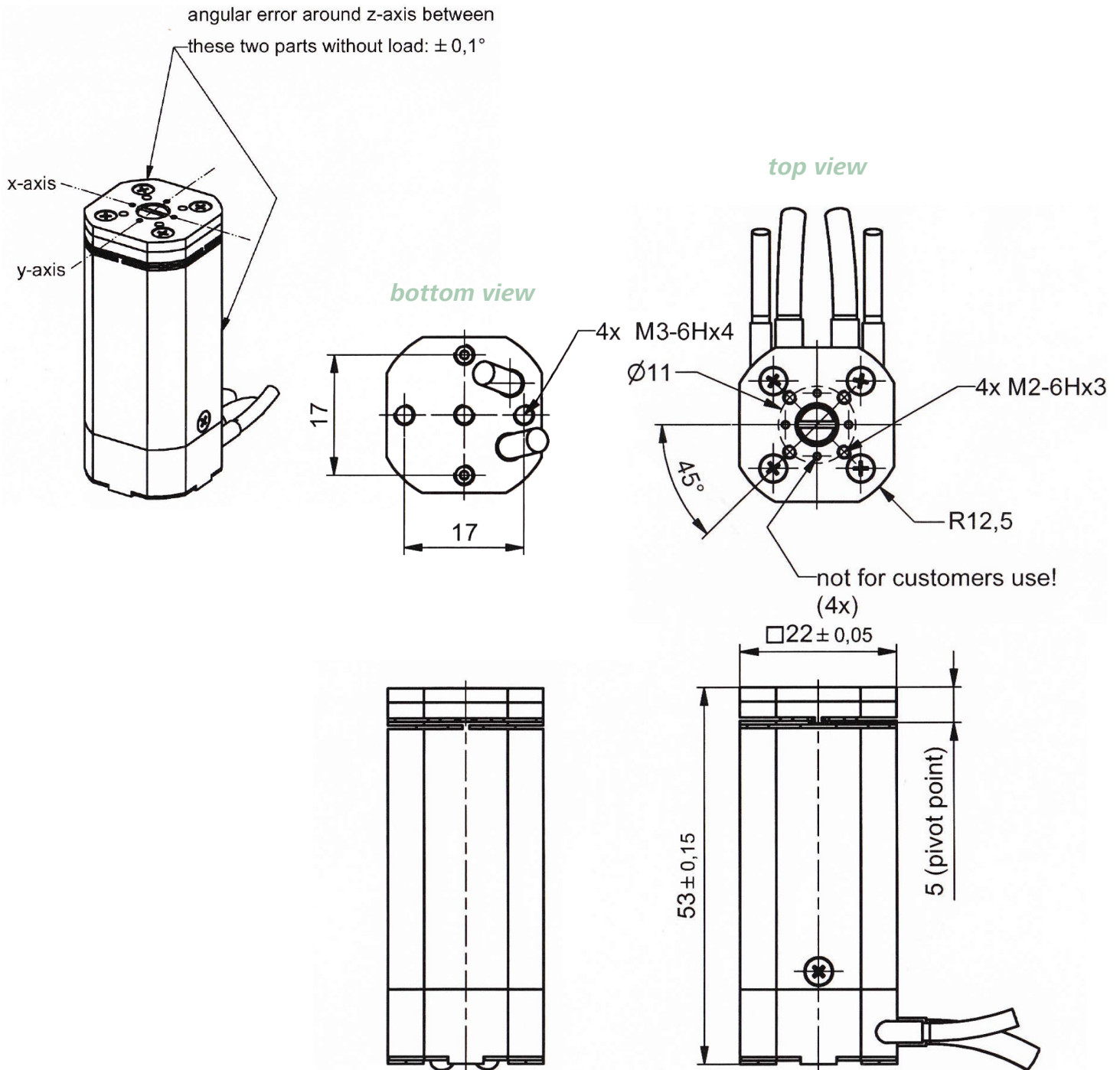

Dimensions given in mm.

We reserve the right to make changes to technical data and designs in the interest of technical progress.

piezosystem jena GmbH
Tel: +49 (3641) 66880
E-Mail: info@piezojena.com

piezosystem jena, Inc.
Tel: +1-508-634-6688
E-Mail: contact@psj-usa.com

www.piezosystem.com