

USER GUIDE

Digital or Analog Control System Instruments LFI3751 Temperature Controller High Precision Controller with Autotune PID



CONTENTS

	PAGE
GENERAL OVERVIEW	2
EXTENDED TABLE OF CONTENTS	3
LFI-3751 SERIES TEMP CONTROLLER SAFETY	4
PANEL & PIN DESCRIPTIONS	5
QUICK CONNECT GUIDE	8
ELECTRICAL SPECIFICATIONS	14
OPERATING INSTRUCTIONS	15
REMOTE OPERATING INSTRUCTIONS	34
ADDITIONAL TECHNICAL INFORMATION	63
TROUBLESHOOTING	66
MECHANICAL SPECIFICATIONS	67
CABLING SPECIFICATIONS	68
DECLARATION OF CONFORMITY	70
CERTIFICATION AND WARRANTY	71

ORDERING INFORMATION

PART NO	DESCRIPTION
LFI3751 Digital	±5A, 45W Temp Controller Digital Instrument
LFI3751 Analog	±5A, 45W Temp Controller Analog Instrument
WCB401	RS-232 Cable, 6-ft, DB 25-9 Pin
WCB402	RS-232 Cable, 6-ft, DB 25-25 Pin
WCB403	RS-232 Cable, 2-ft, DB 25-25 Pin
WCB404	USB-RS232 Adapter Cable
WCB316	LD MOUNT Cable for the LFI3751



Applies to Product Revision C
© January 2026



GENERAL OVERVIEW

FEATURES

- Two models: Analog & Digital
- Output Current: ± 5 A
- Compliance voltage of ± 9.5 V
- Up to 45 W output power
- Stability better than 0.002°C with thermistor
- Compatible with a variety of sensors
 - » Thermistors
 - » RTDs
 - » IC Sensors
- Safety features protect your research
 - » Adjustable current limit to avoid over-driving and damaging the cooler or heater
 - » Temperature limits on the load with shutdown if over- or under-temperature is reached
- CE Compliant
- Autotune PID for characterizing the TEC or RH load and calculating optimum control loop settings for P, I, and D
- Complete command set for remote control from computer
- LabVIEW® Drivers
- Benchlink Software to simulate the front panel control from your PC
- Addressable RS-232 or USB
- Feature-rich for research projects
- Automatic temperature scan function
- Sophisticated error handling
- All instrument documentation and software are provided on Wavelength Electronics' website
- AC Voltage from 100 or 240 VAC, 50-60 Hz power-line frequency

LabVIEW is a trademark of National Instruments.

PRECISION & STABILITY

The LFI-3751 with Autotune PID is a high performance temperature controller instrument specifically designed for sensitive applications. This instrument is capable of driving up to ± 5 A of output current with a compliance voltage of ± 9.5 V.

This instrument offers unique features: *Autotune* PID, *Autoranging* sensor bias currents, *Addressable* RS232 and USB control, free *LabVIEW* drivers, and *Benchlink* software for simulating front panel control from your PC.

EASY INTEGRATION

From the front panel, easily adjust temperature limits, current limits, setpoint, PID control values, sensor calibration data, and enable or disable output current. The 4-digit display shows actual or setpoint temperature or resistance, output current and voltage.

An Analog control model is available which includes remote analog setpoint input. The Digital option provides better setpoint resolution and stability with low-resolution sensors such as RTDs. This option also offers improved overshoot suppression, 50% faster settling times, and faster calibration.

AUTOTUNE PID

Autotune PID algorithm characterizes the thermoelectric cooler (TEC) or heater and determines the optimal PID control coefficients with a push of a button. These terms are user-adjustable and, when properly configured, will quickly settle the load temperature with minimal overshoot and ringing.

With Wavelength's plug and play instrument, you have the ability to quickly set the controls using either the instrument touchscreen or a remote computer.

APPLICATIONS

The advanced and reliable circuitry of the LFI3751 instruments achieve better than 0.002°C temperature stability with thermistors.



The ultra-stable temperature controller instrument is particularly reliable for diverse fields such as medical, defense, quantum technology and spectroscopy. Applications include fluorescent spectroscopy for hypoxia detection, frequency combs, medical diagnostics and monitoring equipment.

EXTENDED TABLE OF CONTENTS



		MEASURING ACTUAL TEMPERATURE OR RESISTANCE	44
		SETTING THE LIMIT CURRENTS	44
SAFETY	4	SETTING TEMPERATURE LIMITS	45
FRONT PANEL DESCRIPTION	5	AUTOTUNE PID & SETTING THE P, I, AND D CONSTANTS	45
REAR PANEL DESCRIPTION	6	SETTING TEMPERATURE SETPOINT	46
		SETTING RESISTANCE SETPOINT	47
QUICK CONNECT GUIDE	8	ENABLING AND DISABLING THE OUTPUT CURRENT	47
PREPARING LFI		MEASURING THERMOELECTRIC CURRENT AND VOLTAGE	48
GENERAL OPERATING STEPS		MEASURING AUXILIARY SENSOR TEMP.	48
FRONT PANEL OPERATION	11	SETTING GAIN FOR ANALOG INPUT SIGNAL	49
		CHECKING THE ALARM STATUS	49
ELECTRICAL SPECIFICATIONS	14	REVERTING TO LOCAL MODE	50
		ENTERING THE PASSWORD	50
OPERATING INSTRUCTIONS	15	READING SERIAL & MODEL NUMBERS, FIRMWARE VERSION	51
CONTROLLING TEMP WITH THERMISTORS	16	CALIBRATION - SENSOR BIAS CURRENT & AD590 SENSE RESISTANCE	51
CONTROLLING TEMP WITH RTDS	18	CALIBRATION - ACT T, TE I, TE V UNCALIBRATED VOLTAGES	53
CONTROLLING TEMP WITH AN AD590	21	CALIBRATION - MEASUREMENT SLOPES & OFFSETS	53
CONTROLLING TEMP WITH AN LM335	22	CALIBRATION - SET T SLOPES & OFFSETS	54
AUTOTUNE PID OPERATION	24	CALIBRATION - TE LIMIT CURRENT SLOPES & OFFSETS	55
SENSOR ERROR CONDITION	28	RESTORE CALIBRATION DEFAULTS	56
SETTING LIMIT CURRENTS	28	DIAGNOSTIC - LAMP CONTROL	57
SETTING TEMPERATURE LIMITS	29	DIAGNOSTIC - SWITCH STATUS	57
MANUALLY SETTING THE P, I, & D CONSTANTS	30	DIAGNOSTIC - DIGI-POT STATUS	58
SETTING OPERATING TEMP OR RESISTANCE	31	END CODE REFERENCE	59
ENABLING OUTPUT CURRENT	31	CALCULATING FCS	60
MEASURING TEC CURRENT OR VOLTAGE	32	EXAMPLE BASIC CONTROL PROGRAM FOR IBM PC COMPATIBLE MACHINES	61
MEASURING AUXILIARY THERMISTOR TEMP	32		
SETTING THE RS-232 ADDRESS	33	ADDITIONAL TECHNICAL INFORMATION	63
OPERATING WITH RESISTIVE HEATERS	33	TROUBLESHOOTING	66
		MECHANICAL SPECIFICATIONS	67
REMOTE INTERFACE REFERENCE	34	CABLING SPECIFICATIONS	68
RS-232 INTERFACE CONFIGURATION	34	CERTIFICATION AND WARRANTY	70
RS-232 COMMAND AND RESPONSE PACKET FORMATS	35		
STANDARD COMMAND CODE LISTING	37		
CALIBRATION COMMAND CODE LISTING	39		
END CODE LISTING	39		
DIAGNOSTIC COMMAND CODE LISTING	40		
STARTING RS-232 COMMUNICATION WITH THE LFI-3751	41		
CONFIGURING THE SENSOR	41		

LFI-3751 SERIES TEMPERATURE CONTROLLER SAFETY





DEFINITIONS

	CHASSIS GROUND Symbol
	CAUTION: A condition that has the potential to cause damage to property or instrument.
	WARNING: A condition that has the potential to cause bodily harm or death.

CAUTIONS

	The LFI3751 instrument has no user-serviceable parts. Other than the fuses, the LFI3751 instrument is not designed to be maintained by the user nor does it contain any parts that can be repaired by the user. All maintenance and repairs must be performed by Wavelength or the warranty will be void.
	Use a soft cloth to remove dust from the LFI3751 instrument. Do not expose the LFI3751 instrument to any liquids, sprays, or solvents. To avoid electrical shock, unplug the power cord before cleaning the instrument.
	Before connecting to the power source, make sure the correct cables for your area are set.

WARNINGS

	Position the LFI3751 instrument so that access to the Main Power On/Off switch on the back panel is easily accessed.
	Do not use the LFI3751 instrument if there is evidence of damage from shipping; damaged equipment can present significant safety hazards. If you suspect the LFI3751 instrument is damaged, contact Wavelength technical support before attempting to operate the instrument.
	To avoid electrical shock, use the recommended earth-grounded power cables and properly earth-grounded, 3-prong receptacles only. Failure to follow this precaution can result in severe injury.
	The instrument may not be operated at measuring category II, III, and IV mains power circuits. In accordance with EN 601010-1:2010, the instrument has been designed without a rated measuring category and may only be used at direct voltage circuits with up to 240VAC without transient overvoltages Operating safety is no longer assured in the event of modification or alteration. The instrument may only be opened by authorized service technicians. Never operate the instrument at a higher voltage than specified in the technical data. The instrument may otherwise be destroyed or permanently damaged.

GENERAL

- **IMPORTANT:** See the User Guide for installation instructions before connecting the LFI3751 instrument to the AC power supply or to a load. The User Guide is located online or on the flash drive included with the instrument.
- Observe all Cautions and Warnings both in the User Guide and on the instrument.
- This instrument is designed to be safe to at least the following conditions: indoor use, 6500 ft (2000 m), 80% max. relative humidity for temperatures up to 31°C and decreasing linearly to 50% relative humidity at 40°C, transient overvoltages to Overvoltage Category 2, and environmental conditions to Pollution Degree 2.
- Use the LFI3751 instrument as specified in this guide. If not, the protection provided by this instrument may be impaired and the warranty will be voided.
- The LFI3751 instrument is intended to be used to control thermoelectrics, resistive heaters, and other similar equipment. Please contact the Wavelength Electronics for other possible applications.
- The LFI3751 instrument must not be operated in explosion endangered environments.
- Do not operate the LFI3751 instrument where liquids are present or used and do not spill liquid on the instrument.
- The safety of any system that incorporates the use of the LFI3751 instrument is the sole responsibility of the system assembler. This includes assembly, mounting, location, special ambient or application conditions, and connections within the system.
- Operating outside of the conditions specified in the User Guide are not recommended for safety reasons.
- Proper setup in the end user's environment includes:
 - » Adequately sized thermoelectric and heatsink to properly manage the heat dissipated by the load.
 - » Securely mounted temperature sensor for accurate temperature control.
 - » Correct connection of the thermoelectric.
 - » Use of the LD Shutdown connection to protect the load.

POWER CORDS

- The power cord acts as the power disconnecting device between the AC mains and LFI3751 instrument.
- This equipment is grounded through the AC power cord grounding conductor.
- Use only the earth-grounded power cords that are recommended in this user guide.
- Route power cords and other cables so that they cannot be damaged.
- Position the LFI3751 instrument in a location that makes it easy to quickly disconnect the power cord.
- To avoid fire hazard, use only the specified power cords with the correct grounding, voltage, and current ratings.

FUSES

- Disconnect the power to the LFI3751 instrument before changing the fuses.
- To prevent damage to the LFI3751 instrument when replacing fuses, locate and correct the problem that caused the fuse to blow before re-applying power.
- To avoid fire hazard, use only the specified fuse with the correct type number, voltage, and current ratings, and use only the recommended replacement parts.

PANEL & PIN DESCRIPTIONS

LFI-3751 Front Panel Description	5
LFI-3751 Rear Panel Description	6
LFI-3751 Pin Description	6

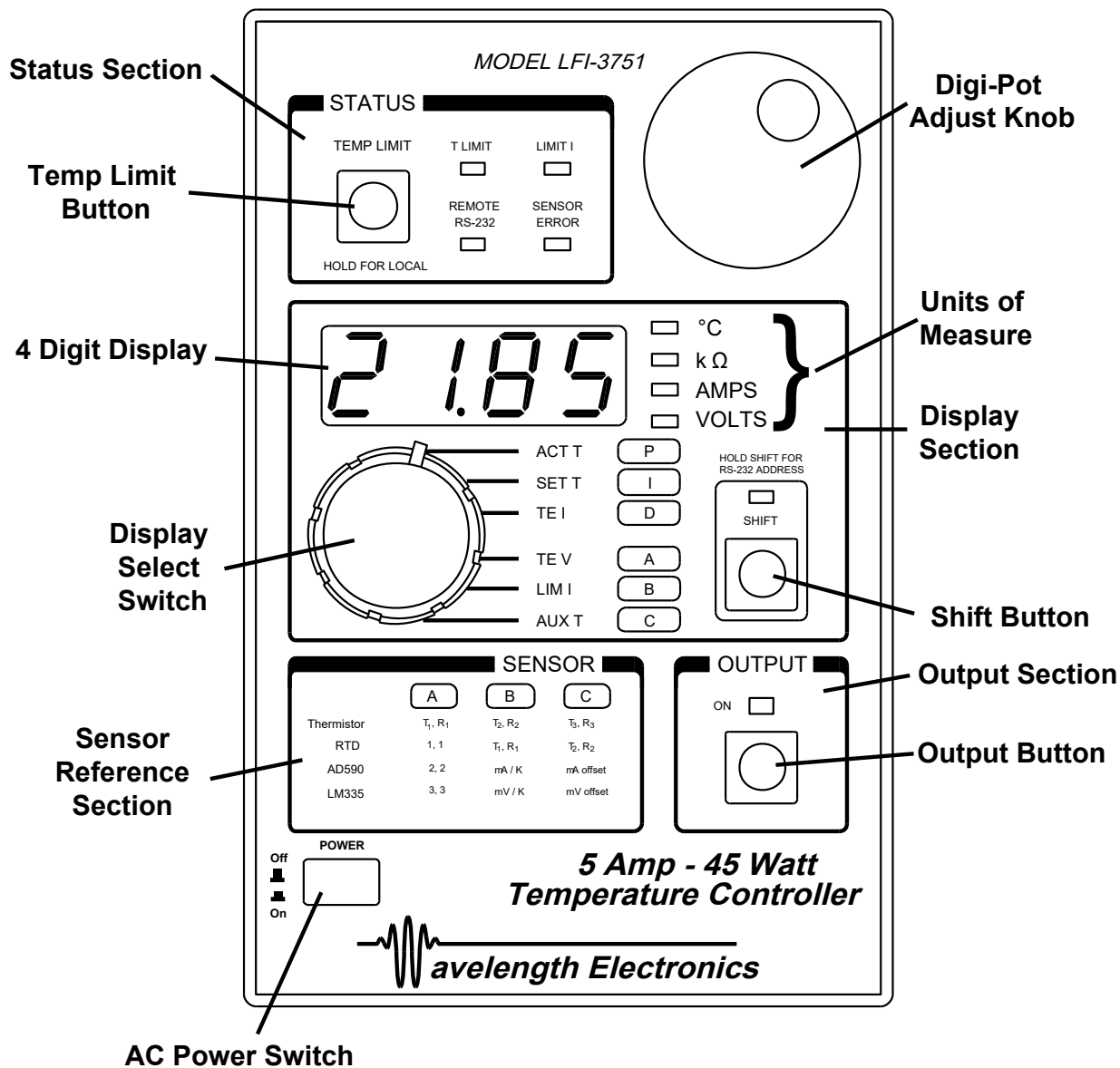

Figure 1. LFI-3751 Front Panel Description

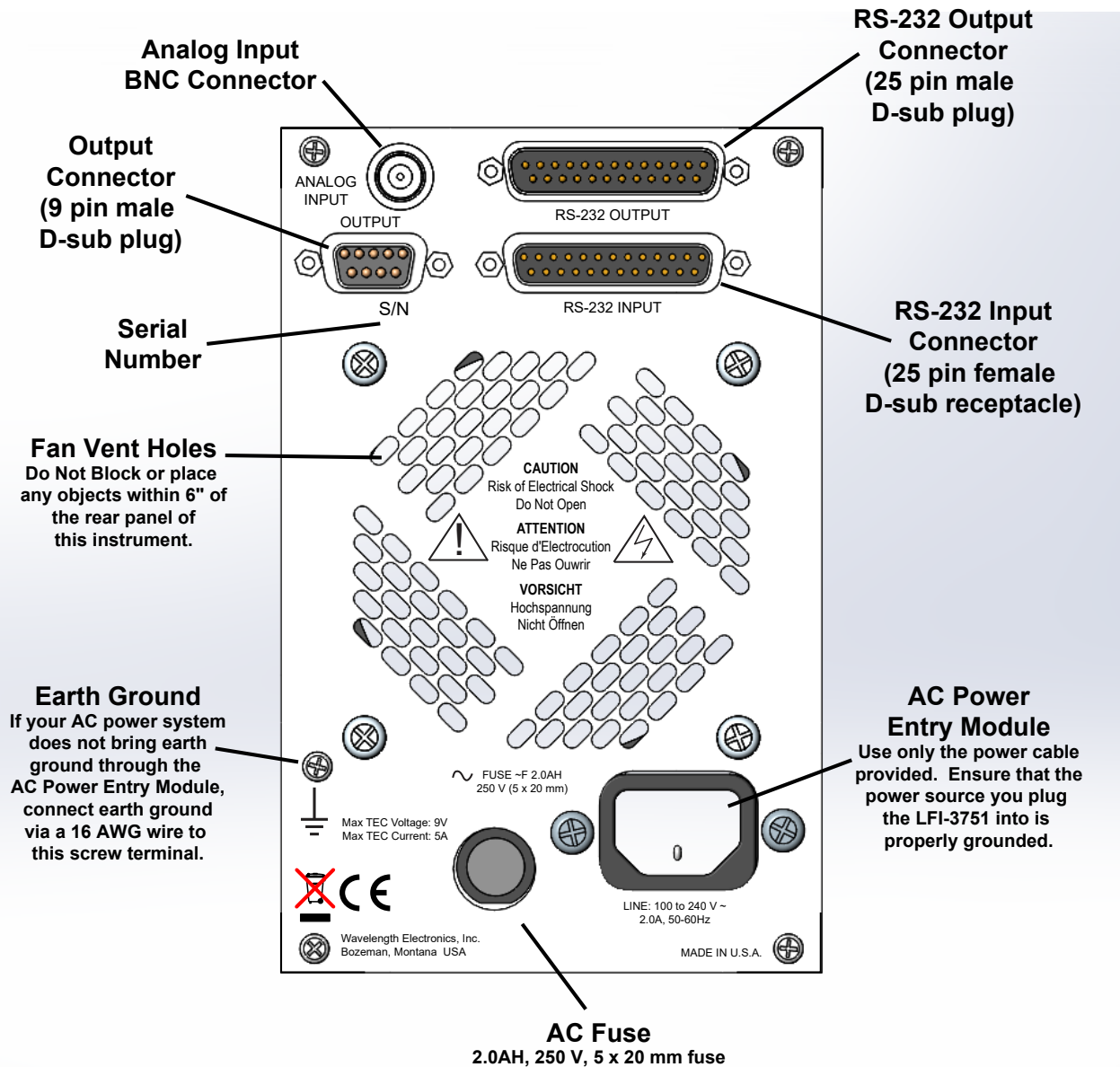

Figure 2. LFI-3751 Rear Panel Description

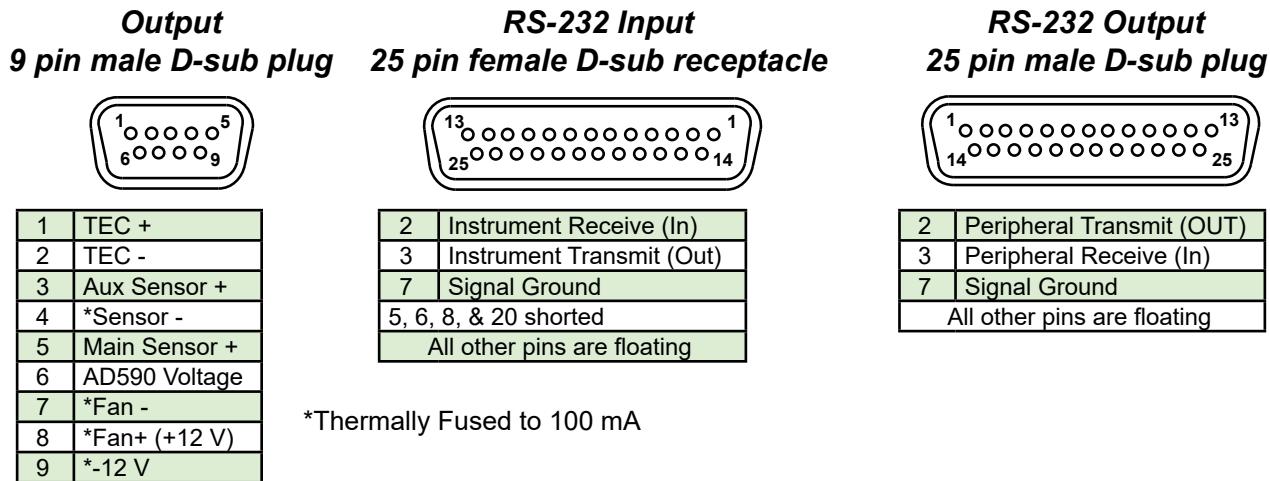

Figure 3. LFI-3751 Pin Description

BNC CONNECTOR [USED WITH ANALOG VERSION ONLY]

Analog Input BNC

Input a 0 to ± 10 V analog signal to adjust the setpoint remotely. The sum of the front panel **SET T** setting and analog input determine the control temperature. If not using the analog input, install the 50 Ω BNC terminator provided with the unit to minimize electrical noise and protect against electro-static discharge. The transfer functions change according to the sensor type and bias current.



Analog Input Transfer Functions

Thermistors & RTDs (10 μ A or 100 μ A)	10 k Ω / V
Thermistors & RTDs (1 mA or 10 mA)	100 Ω / V
LM335, AD590, Thermocouples	10 $^{\circ}$ C / V

- Example: With a thermistor biased with 100 μ A, if **SET R** is 12 k Ω , if you input +0.2 V at the **Analog Input BNC**, the setpoint becomes:

$$12 \text{ k}\Omega + (0.2 \text{ V}) (10 \text{ k}\Omega / \text{V}) = 14 \text{ k}\Omega$$

- *RS-232 Command:* [**MOD Gain Configuration**]

AC POWER

AC Power Entry Module

The **AC Power Entry Module** on the rear panel is designed to accept input voltages from 100 to 240 VAC. Ensure that the power source you plug the temperature controller into is properly grounded.

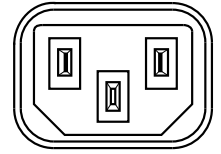

~ LINE:
100 to 240 V
~2.0A, 50-60Hz

Earth Ground Connection

If your AC power system does not bring earth ground through the **AC Power Entry Module**, then connect earth ground via a 16 AWG wire to this screw terminal.



QUICK CONNECT GUIDE

PREPARING THE LFI

CONNECT POWER CORD AND POWER ON LFI

Ensure the power source you plug the temperature controller into is properly grounded. The power supply AC input auto-ranges for either 110 or 220 VAC. Once the **AC Power Switch** on the front panel is pressed in, all LEDs on the front panel will light up while the temperature controller performs its power-on self test. After the test, the temperature controller is ready for normal operation.

PERFORM A COMPLETE SELF TEST

The complete self test is a more extensive set of tests than those performed at power-on. Hold down the **Shift Button** as you power the unit on with the **AC Power Switch**. A complete self test will start after holding the **Shift Button** for three seconds. If the self test is successful, "PASS" is displayed. If the self test is not successful, "FAIL" is displayed. If "FAIL" is displayed, contact Wavelength Electronics.

GENERAL OPERATING STEPS

STEP 1 - WIRE OUTPUT CONNECTOR

This 9-pin D-Sub male plug requires a mating female receptacle. Wire the thermoelectric module to Pins 1 (positive lead) and 2 (negative lead). Wire the sensor (a thermistor in this example) to Pins 4 & 5. The remaining connections are optional. If you need a fan to cool a heatsink, wire a +12 V fan (100 mA maximum) to Pins 7 & 8. If you need a second sensor to monitor an auxiliary zone (ambient, heatsink, etc.) wire a 10 kΩ thermistor to Pins 3 & 4. Install the 50 Ω BNC terminator on the **Analog Input BNC** on the rear panel.

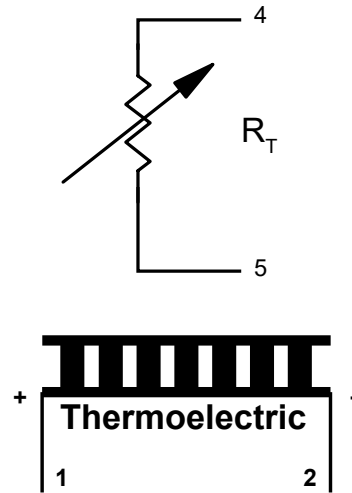

OUTPUT CONNECTOR 9 PIN D-SUB PLUG (MALE) PINOUT	
1	TEC +
2	TEC -
3	Aux Sensor +
4	*Sensor -
5	Main Sensor +
6	AD590 Voltage
7	*Fan -
8	*Fan + (+12V)
9	*-12 V

*Thermally Fused to 100 mA

STEP 2 - CONFIGURE SENSOR

The change in resistance vs. temperature of a thermistor can be modeled by the Steinhart-Hart Thermistor equation.

$$\frac{1}{T} = X_1 + X_2 \ln(R) + X_3 (\ln(R))^3$$

where T is temperature (Kelvin) and R is resistance (Ohms). The LFI calculates the three coefficients (X_1 , X_2 , & X_3) from three (Temperature, Resistance) data pairs that you enter. Using the Steinhart-Hart equation, the temperature controller converts the thermistor resistance to a displayed temperature. Calibration is more accurate when the data pairs are close to the desired operating temperature. For this example, 25°C is the goal. Calibrating this 10 kΩ thermistor with 10°C, 25°C, and 40°C will offer a wide range of operation as well as 0.01°C accuracy.

QUICK START CONT.

Rotate the **Display Select Switch** to **A** and toggle the **Shift Button ON**. A temperature and a resistance will alternate on the display. See the unit of measure LEDs to determine if it is the temperature or resistance value. For the 10 kΩ thermistor in this example, we choose **A, B,** and **C** to be (10°C, 19.9 kΩ), (25°C, 10 kΩ), and (40°C, 5.326 kΩ) respectively in **Figure 4**.

Figure 4. Resistance vs. Temperature for TCS-610 10 kΩ Thermistor

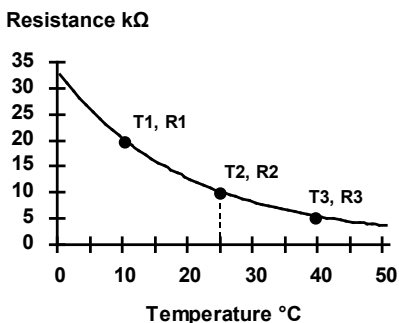

This information is available from the thermistor manufacturer (usually in table form). Use the **Digi-Pot Adjust Knob** to change either value when it is displayed. Rotate the **Display Select Switch** to **B** then **C**, making any necessary adjustments.

STEP 3 - SET LIMIT CURRENT

With the output off, set the limit current below the thermoelectrics' maximum current (± 5 A). Assume the example thermoelectric's maximum is 1.25 A. Set the Limit Current to 1.0 A. Rotate the **Display Select Switch** to **LIM I** with the **Shift Button OFF**. The positive and negative limits will alternate on the display. Rotate the **Digi-Pot Adjust Knob** until 1.00 and -1.00 alternate.

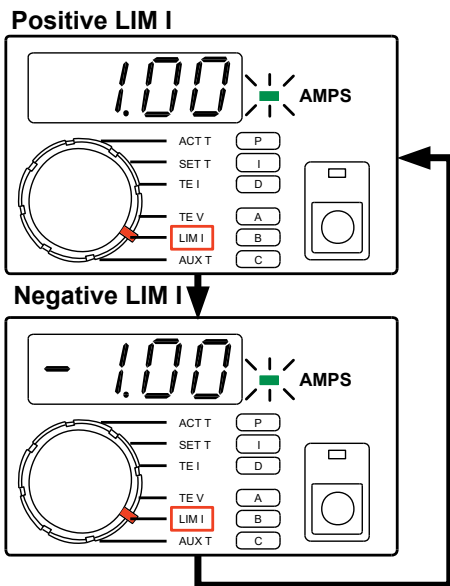

STEP 4 - SET TEMPERATURE LIMIT

Press and release the **TEMP LIMIT Button** (-199.9 to +199.9°C). Two numbers will alternate on the display. If the thermistor temperature exceeds these limits, the output current will be turned off. The numbers will alternate three times before the display reverts to the parameter selected by the **Display Select Switch**, in this case, **LIM I**. Assume that the load should not be allowed to freeze (0°C) and should not exceed 55°C. Rotate the **Digi-Pot Adjust Knob** until 0°C and 55°C are displayed. The highest temperature is selected as the **High T LIMIT** and the lowest temperature is used as the **Low T LIMIT**.

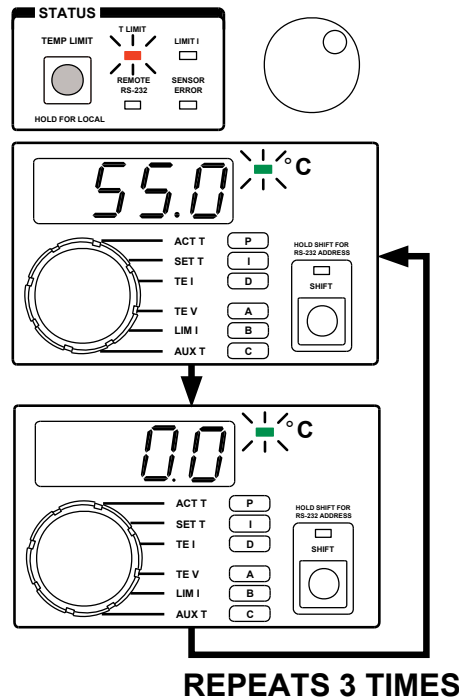

STEP 5 - DISPLAY AND ADJUST SETPOINT TEMPERATURE

Rotate the **Display Select Switch** to **SET T** and toggle the **Shift Button OFF**. The setpoint temperature is displayed. Rotate the **Digi-Pot Adjust Knob** until 25°C is displayed.

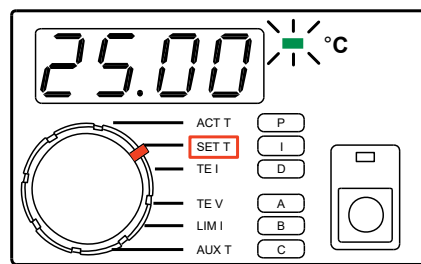

QUICK START CONT.

STEP 6 - BEGIN AUTOTUNE OPTIMIZATION

Autotune: After setting the current limits and temperature setpoint, rotate the **Display Select Switch** to **P** and toggle the **Shift Button ON**. Use the **Digi-Pot Adjust Knob** to change the value. To select Autotune optimization, adjust the P value to display AutS or AutD.

AutS: Setpoint Response Autotune Optimization

Autd: Disturbance Rejection Autotune Optimization

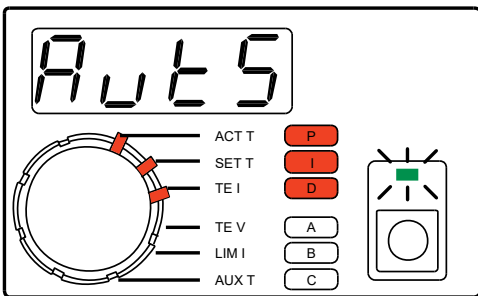

You determine what kind of control loop the Autotune will use based on your settings for the I and D terms. If set to zero, that control term will not be used. The following chart shows which control modes are available and the appropriate I and D settings. Rotate the **Display Select Switch** to I and D, making any necessary adjustments with the **Digi-Pot Adjust Knob**.

CONTROL MODE	I	D
PID	non-zero	non-zero
PI	non-zero	OFF = zero
PD	OFF = zero	non-zero
P	OFF = zero	OFF = zero

For this example, adjust **P** to AutS, **I** to 1.0, and **D** to 1.0.

Manual setting: adjust **P** to a value other than AutS or Autd.

Begin Autotune Optimization by enabling the Output Current.

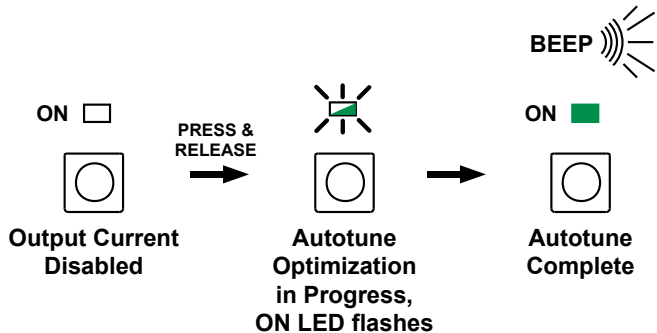

The time to complete an Autotune optimization sequence varies from load to load. While tuning, the **ON LED** will flash. When complete, the LFI will beep once and the **ON LED** will light solid.

Three audible beeps indicate if the Autotune sequence is aborted. The **ON LED** is not lit. If the actual sensor temperature exceeds the high or low temperature limits the optimization will abort.

More information on the LFI-3751 Autotune feature can be found on **page 24**.

Output current will remain ON after successful Autotune Optimization.

STEP 7 - ENABLE THE OUTPUT CURRENT

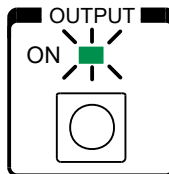

Press the **Output Button** to enable the output current and/or begin the Autotune optimization sequence. The **ON LED** indicator will flash while Autotune optimization is in progress. Once the Autotune sequence is finished, the LFI-3751 will control to the desired operating temperature entered in **Step 5**. Refer to **page 24**, "Autotune PID operation" for more detail.

STEP 8 - MEASURE ACTUAL TEMPERATURE

Rotate the **Display Select Switch** to **ACT T (Shift Button OFF)** to monitor the load temperature. **ACT T** temperature now approaches the **SET T** temperature.

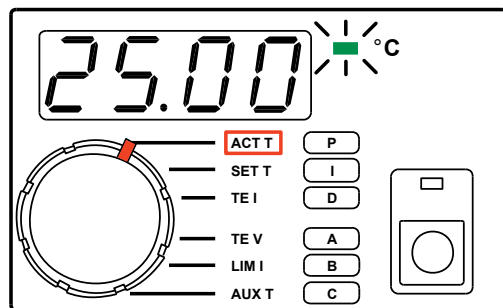

STEP 9 - MEASURE THERMOELECTRIC CURRENT AND VOLTAGE

Rotate the **Display Select Switch** to **TE I (Shift Button OFF)** to monitor the current flowing through the thermoelectric. Rotate the **Display Select Switch** to **TE V (Shift Button OFF)** to monitor the voltage across the thermoelectric.

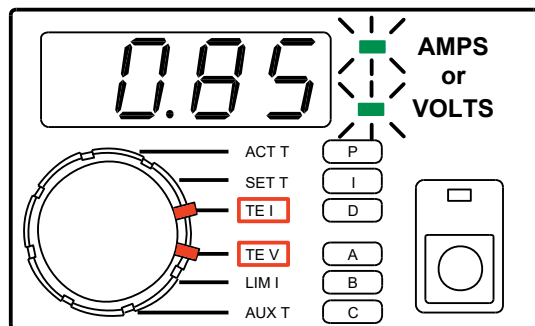

FRONT PANEL OPERATION

OPERATION LEGEND

 While displayed, Parameter can be changed by rotating Digi-Pot Adjust Knob

 Digi-Pot Adjust Knob is disabled. Monitor parameter only.

 LED is OFF

 LED is lit SOLID

 LED FLASHES

LIMIT CURRENT LED

LIMIT I



LIMIT I LED flashes:
TE Current is limited by LIM I settings.

WAIT - Most thermal loads require maximum current while initially controlling to temperature. To control properly, the output current must be less than the **LIM I** current setting.

CAUTION: Improperly set LIM I can damage your thermoelectric

ENABLE / DISABLE OUTPUT CURRENT

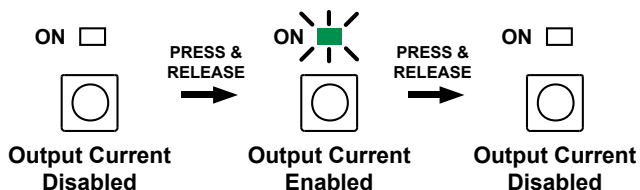

TEMPERATURE LIMIT LED & CORRECTION TEMPERATURE LIMIT ERROR

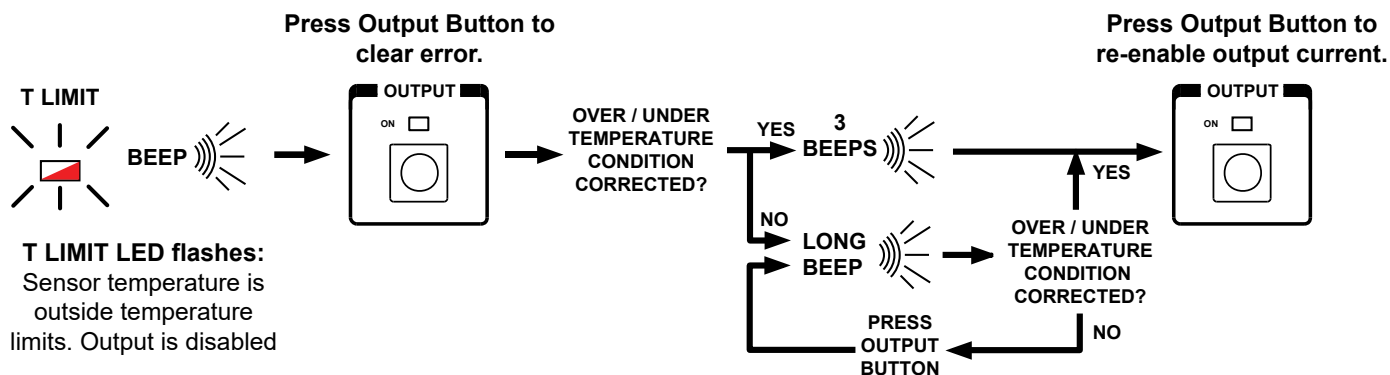

SENSOR ERROR LED & CORRECTING SENSOR ERROR

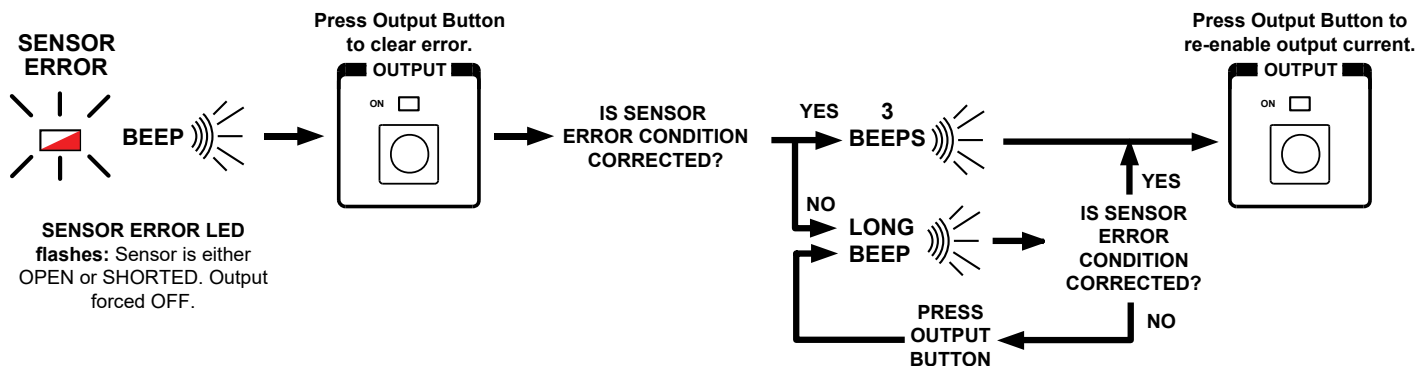

FRONT PANEL OPERATION CONTINUED

ADJUSTING RS-232 ADDRESS

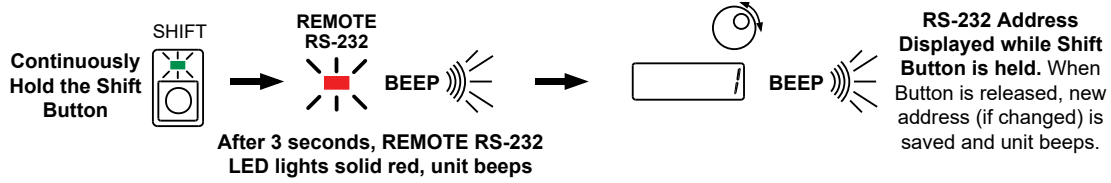

REMOTE RS-232 LED

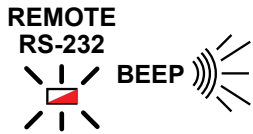

REMOTE RS-232 LED flashes, unit BEEPS:
RS-232 communication is initiated and the port is active.



A flashing **RS-232 LED** indicates active communication between computer and instrument.

A solid **RS-232 LED** indicates the instrument is under remote RS-232 control, but communication between computer and instrument is not active.

ENABLE / DISABLE OUTPUT CURRENT DURING CONTINUOUS RS-232 OPERATION

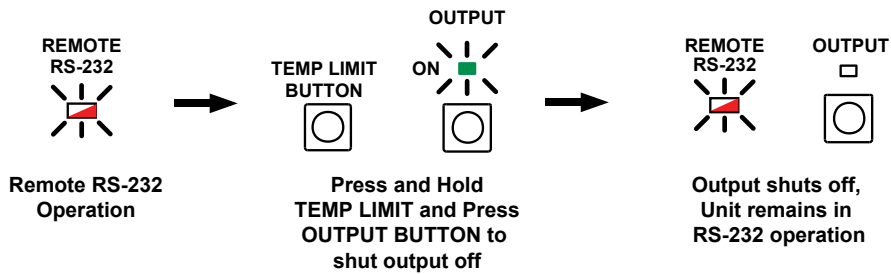

REVERT TO LOCAL MODE OPERATION

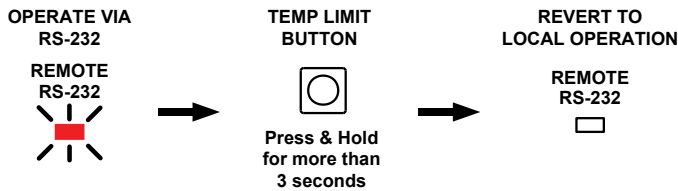

FRONT PANEL OPERATION CONTINUED

DISPLAY SECTION

SHIFT OFF		SHIFT ON	
ACT T	-199.9°C to +199.9°C OR 0 to 499.9 kΩ	°C OR kΩ	P AutS or Autd (Autotune PID) or 1 to 100 Amps / Volt
SET T	-199.9°C to +199.9°C OR 0 to 499.9 kΩ	°C OR kΩ	I OFF (0) OR 0.4 to 10.0 secs.
TE I	- 5.00 to +5.00 Amps	AMPS	D OFF (0) OR 1 to 100 secs.
TE V	-12.0 to +12.0 Volts	VOLTS	A [A1] 10.00 °C [A2] 19.90 kΩ
LIM I	0.00 to +5.00 Amps POSITIVE 1.00 AMPS -5.00 to 0.00 Amps NEGATIVE -1.00 AMPS	AMPS	B Thermistors or RTDs (T, R) data [B1] 25.00 °C [B2] 10.00 kΩ AD590, LM335, Slope [B1] only 1.00
AUX T	-8.00°C to +150.00°C (typical)	°C	C Thermistors or RTDs (T, R) data [C1] 40.00 °C [C2] 5.33 kΩ AD590, LM335, Offset [C1] only 1.00

DEFAULT SENSOR CONFIGURATION

SENSOR TYPE	A		B		C	
	[A1]	[A2]	[B1]	[B2]	[C1]	[C2]
Thermistor	10°C	19.9 kΩ	25°C	10 kΩ	40°C	5.326 kΩ
RTD	1	1	0°C	0.100 kΩ	100°C	0.139 kΩ
AD590	2	2	1 μA / K	-	0 μA	-
LM335	3	3	10 mV / K	-	0 mV	-

ELECTRICAL SPECIFICATIONS

PARAMETER	SYMBOL	MIN	TYP	MAX	UNIT
ABSOLUTE MAXIMUM RATINGS					
Output Current				± 5.0	A
Output Power				45 W	Watts
Operating Temperature, case	80% Relative Humidity to 30°C	0		55	°C
Storage Temperature		-40		70	°C
Dimensions:	W x D x H	4.25 x 12 x 6.5 (108 x 305 x 165)			inches (mm)
State Storage		Power OFF State Automatically Saved			
Weight		2.27 5			kg lbs

PARAMETER	TEST CONDITIONS	MIN	TYP	MAX	UNIT
TEMPERATURE CONTROL					
Short Term Stability, 1 hour ❶	10 kΩ thermistor 100μA	<0.002			°C
Long Term Stability, 24 hours ❶	10 kΩ thermistor 100μA	<0.005			°C
Setpoint Resolution		12 bit D to A			
Acoustic Noise			26		dBa
Warm-Up Time			1		hour

TEC OUTPUT					
Bipolar Output Current		± 5.0			A
Compliance Voltage		± 9.5			V
Current Limit Range		0		± 5	A
Control Loop		P, PI, PD, PID			
Proportional Gain, adjustable	AutS, Autd	0		100	A / V
Integrator Time Constant, adjustable	(OFF or adjustable)	0.4		10	s
Differentiator, adjustable	(OFF or adjustable)	1		100	s

POWER SUPPLY		VALUE			
AC Power Supply		100 - 240 VAC (Auto-detect)			
Power-Line Frequency		50 / 60			Hz
Power Consumption		160 VA peak 25 Watt average (Output OFF) 55 Watt average (Output ON)			

DISPLAY (4 DIGIT)					
Temperature		-199.9		+199.9	°C
Resistance		0		499.9	kΩ
TEC Current		-5.00		+5.00	A
TEC Voltage		-9.99		+9.99	V
Measurement Resolution		15 bit A to D			

SENSORS					
Thermistors		0		499.9	kΩ
RTDs		0		499.9	kΩ
AD590					
LM335					

❶ Stability quoted for a typical 10 kΩ thermistor at 100 μA bias current. One hour to rated stability.

OPERATING INSTRUCTIONS

WHAT'S IN THE BOX

- LFI-3751 Temperature Controller Instrument
- Power Cable, type appropriate for final location
- 9 pin D-Sub receptacle (solder cup) and metal hood
- 5 x 20 mm AC fuses (x2)
- 50 Ω BNC terminator (Analog version only)
- TCS610 10 k Ω Thermistor
- LFI3751 Safety Card

REQUIRED AND OPTIONAL EQUIPMENT

FOR SET UP

- Test load (optional) OR
- Thermoelectric or Resistive Heater and temperature sensor for feedback

COMPUTER REQUIREMENTS FOR REMOTE OPERATION ONLY (OPTIONAL)

- The Benchlink Installer is not compatible with 64-bit operating systems. Contact Tech Support for details if using a 64-bit operating system.

ESD INFORMATION

Before proceeding, it is critical that you take precautions to prevent electrostatic discharge (ESD) damage to the load. ESD damage can result from improper handling of sensitive electronics, and is easily preventable with simple precautions.

For more information regarding ESD, see Application Note [AN-LDTC06: Basics: Electrostatic Discharge \(ESD\)](#).

We recommend that you always observe ESD precautions when operating the LFI-3751.

REMOTE OPERATION

The LFI-3751 instrument can be controlled by a remote computer using a [LabVIEW Virtual Instrument application](#) to simplify computer control and a [Benchlink software](#) to simulate the front panel control from your PC.

(NOTE: The Benchlink Installer is not compatible with 64-bit operating systems. A workaround for Benchlink install is available. Contact Tech Support for details if your application uses the Windows 64-bit OS and Benchlink front panel emulation control.)

THEORY OF OPERATION

The LFI-3751 is an autotune temperature controller that delivers bidirectional current to Peltier Effect thermoelectric coolers (TEC), or unidirectional current to resistive heaters (RH).

The fundamental operating principle is that the controller adjusts the output drive current in order to change the temperature of the sensor that is connected to the thermal load. The goal is to make the sensor temperature match the setpoint temperature, and then keep them equal in spite of changes to ambient conditions and variations in thermal load.

While output is enabled, the controller continuously compares the setpoint temperature and the actual sensor temperature. If there is a difference between the two, the controller adjusts the output current — thereby driving the TEC or heater to heat or cool — until the difference is zero.

The controller includes features that protect the load from damage, and also make it more versatile in a wide array of applications.

Current Limits: The adjustable current limits must be set correctly in order to avoid over-driving and damaging the TEC or heater.

Control Loop: The controller employs a smart Proportional-Integral-derivative (PID) control loop to adjust the drive current. The terms are user-adjustable and, when properly configured, will quickly settle the load temperature with minimal overshoot and ringing.

Autotune: The LFI-3751 is capable of automatically characterizing your TEC or RH load and calculating optimum control loop settings for P, I, and D.

Temperature Limits: Set high and low temperature limits to disable the TEC or RH current if the temperature limits are exceeded.

GENERAL OPERATING INSTRUCTIONS

CONNECT THE POWER

On the back panel, insert the female end of the AC power cable provided into the **AC Power Entry Module** and then plug the male end into the AC power source.

The **AC Power Entry Module** on the rear panel is designed to accept input voltages from 100 to 240 VAC. The power supply auto-ranges for either 110 or 220 VAC. Ensure that the power source you plug the temperature controller is properly grounded.

If your AC power system does not bring earth ground through the **AC Power Entry Module**, then connect earth ground via a 16 AWG wire to the screw terminal with the earth ground symbol.

SELECT A SENSOR

For sensor configuration, the following notation is used:

A, **B**, or **C** refers to the **Display Select Switch** settings. Each sensor type requires different configuration data. That data entered for **A**, **B**, and **C** changes for each sensor.



T and **R** refer to Temperature and Resistance data pairs used to characterize resistive sensor's response to temperature. Subscripts are used when more than one data pair is required.

Slope and **Offset** are used to characterize the non-resistive sensor's response to temperature changes.

Text in brackets (e.g. **[A1]**) refers to the corresponding RS-232 command.

CONTROLLING TEMPERATURE WITH THERMISTORS

The key to accurately measuring and controlling temperature with a thermistor is properly entering the configuration data. A thermistor's temperature response can be modeled by the Steinhart-Hart equation. To calculate the three Steinhart-Hart coefficients, the LFI-3751 requires three data pairs **A** = (**T**₁, **R**₁), **B** = (**T**₂, **R**₂), and **C** = (**T**₃, **R**₃). Thermistor manufacturers provide this information in a table of Resistance vs. Temperature data. With the Steinhart-Hart equation and coefficients, the LFI-3751 can calculate temperature from thermistor resistance and properly calculate the setpoint resistance from the setpoint temperature. The locations of **A**, **B**, and **C** on the LFI-3751 can be seen in **Figure 5** as well as default configurations.

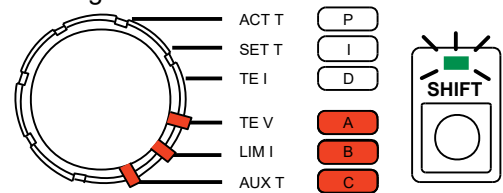

A	T1 = 10.00°C	[A1]
	R1 = 19.90 kΩ	[A2]
B	T2 = 25.00°C	[B1]
	R2 = 10.00 kΩ	[B2]
C	T3 = 40.00°C	[C1]
	R3 = 5.326 kΩ	[C2]

Figure 5. Thermistor Configuration and Default Configuration

Wiring a Thermistor

Wire the thermistor to the Output Connector on the rear panel. Do not exceed 1 meter cable length. Refer to **Sensor Error Condition on page 28** if you can't clear a Sensor Error.

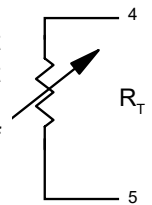

Automatic Bias Current

A fixed bias current, I_{BIAS} , flows from Pin 5, through the thermistor and back into Pin 4 to produce a voltage, V_T . As the thermistor resistance (R_T) changes, the voltage changes. V_T must be maintained between 0 and +5 V for proper operation. The LFI-3751 automatically ranges between four bias currents (10 μA, 100 μA, 1 mA, and 10 mA) to optimize feedback while allowing a wider temperature range of operation. Hysteresis is designed in to produce "bumpless" operation when switching from one bias current to another.

Thermistor Voltage (Pins 4 & 5)

$$V_T = I_{BIAS} \times R_T$$

where V_T is the voltage across Pin 4 and Pin 5, I_{BIAS} is the LFI-3751 bias current, and R_T is the resistance of the thermistor. **Table 1** shows the resistance ranges for each bias current.

Table 1. Bias Current & Sensor Resistance Range

SENSOR CURRENT	RESISTANCE RANGE
10 μ A	25 k Ω to 500 k Ω
100 μ A	2.5 k Ω to 45 k Ω
1 mA	0.25 k Ω to 4.5 k Ω
10 mA	0 k Ω to 0.45 k Ω

Thermistor Temperature vs. Resistance

Temperature can be determined by the Steinhart-Hart equation given the thermistor resistance and the equation coefficients χ_1 , χ_2 , and χ_3 :

$$\frac{1}{T} = \chi_1 + \chi_2 \ln(R) + \chi_3 (\ln(R))^3$$

where T is temperature (Kelvin) and R is resistance (Ohms).

To calculate the Steinhart-Hart coefficients, the LFI-3751 needs three (Temperature, Resistance) data pairs. Enter **A**: (T_1 , R_1), **B**: (T_2 , R_2), and **C**: (T_3 , R_3) through the front panel or [A1], [A2], [B1], [B2], [C1], and [C2] via the RS-232 interface. Using the thermistor resistance vs. temperature chart provided with your thermistor, select three temperatures. These temperatures can be far apart if you're working with a wide temperature range, or close together to optimize the curve fit around one temperature. **Figure 6** shows a typical resistance vs. temperature response.

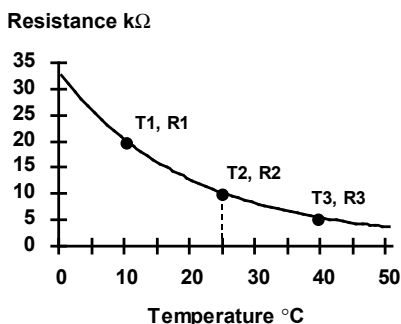

Figure 6. Typical Thermistor R vs. T Response

Entering Data Pair - A (Figure 7)

- Rotate the **Display Select Switch** to **A (Shift Button ON)**. The first two data pairs alternate on the display. One is temperature ($^{\circ}$ C LED lit), the other is the corresponding thermistor resistance (k Ω LED lit).
- Rotate the **Digi-Pot Adjust Knob** to change the value displayed. Default from the factory sets up for a 10 k Ω thermistor (Wavelength P/N TCS-610).

- To display thermistor resistance rather than temperature, enter (0.000, 0.000) for the **A** terms. [**B** & **C** are ignored for resistance display.]
- **A**, **B**, and **C** cannot be adjusted while the output is on.
- Data pairs **A**, **B**, and **C** are saved in non-volatile memory.
- RS-232 Command: [**A1**] = T_1 , [**A2**] = R_1

Display Resolution

TEMPERATURE	-199.9 to -20.0 $^{\circ}$ C
	-19.99 to -2.00 $^{\circ}$ C
	-1.999 to 9.999 $^{\circ}$ C
	10.00 to 99.99 $^{\circ}$ C
RESISTANCE	0 to 9.999 k Ω
	10.00 to 99.99 k Ω
	100.0 to 499.9 k Ω

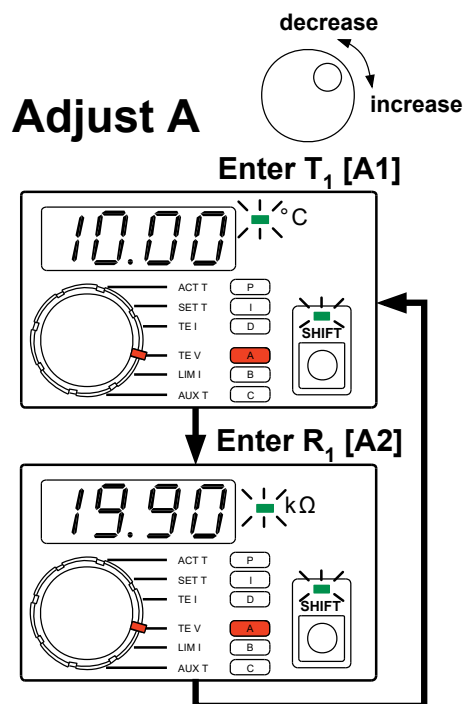

Figure 7. Entering Data Pair A - Thermistor

Entering Data Pairs - B & C

- To enter Data Pairs **B** and **C**, follow the instructions for **Data Pair A** but rotate the **Display Select Switch** to either **B** or **C (Shift Button ON)**. Then adjust the values as needed.
- RS-232 Command: [**B1**] = T_2 , [**B2**] = R_2
- RS-232 Command: [**C1**] = T_3 , [**C2**] = R_3
- Display Resolution is identical to Data Pair **A**.

Display Actual Thermistor Temperature

- Rotate the **Display Select Switch** to **ACT T (Shift Button OFF)** to display the thermistor temperature.
- RS-232 Command: **[ACT T]**

Display Resolution	
-199.9 to	-20.0°C
-19.99 to	-2.00°C
-1.999 to	9.999°C
10.00 to	99.99°C
100.0 to	199.9°C

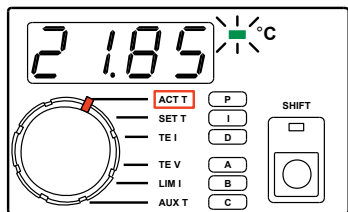

Display Actual Thermistor Resistance

- Enter [0.000, 0.000] for **A** to have the LFI display thermistor resistance (kΩ) when the **Display Select Switch** is rotated to **ACT T (Shift Button OFF)**.
- RS-232 Command: **[ACT R]**

Display Resolution	
0 to	9.999 kΩ
10.00 to	99.99 kΩ
100.0 to	499.9 kΩ

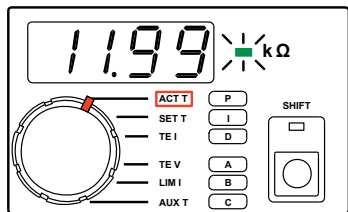

Adjusting Thermistor Resistance Setpoint

- Rotate the **Display Select Switch** to **SET T (Shift Button OFF)**. If (0.000, 0.000) has been entered for **A**, resistance will be displayed.
- To adjust the setpoint, rotate the **Digi-Pot Adjust Knob**. While the knob is rotating, the display will change, but the instrument will not control to the new setpoint until the knob stops moving.
- The decimal point will move to display maximum resolution.
- **SET R** is saved in non-volatile memory.
- Temperature Limits are disabled in Resistive Operating Mode.
- RS-232 Command: **[SET R]**

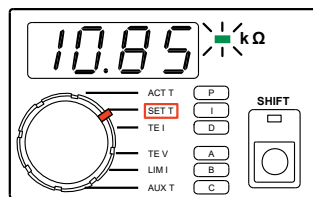

Adjusting Thermistor Temperature Setpoint

- Rotate the **Display Select Switch** to **SET T (Shift Button OFF)**. Temperature will be displayed.
- To adjust the setpoint, rotate the **Digi-Pot Adjust Knob**. While the knob is rotating, the display will change, but the instrument will not control to the new setpoint until the knob stops moving.
- The decimal point will move to display maximum resolution.
- **SET T** is saved in non-volatile memory.
- RS-232 Command: **[SET T]**

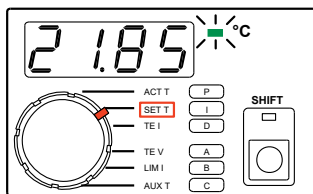
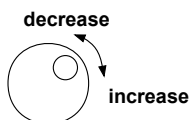

CONTROLLING TEMPERATURE WITH RTDs

The key to accurately measuring and controlling temperature with an RTD is properly entering the configuration data. An RTD's temperature response can be assumed to be linear or more precisely modeled by the Callendar - Van Dusen Curve fit. To indicate that the sensor is an RTD, **A** = (1.000, 1.000). To calculate the linear or Callendar - Van Dusen coefficients, the LFI requires two data pairs **B** = (T_2 , R_2), **C** = (T_3 , R_3). With the appropriate equation and coefficients, the LFI can calculate temperature from RTD resistance and properly calculate the setpoint resistance from the setpoint temperature.

DEFAULT RTD CONFIGURATION

A	= 1.000	[A1]
	= 1.000	[A2]
B	$T_1 = 0.00^\circ\text{C}$	[B1]
	$R_1 = 0.100 \text{ k}\Omega$	[B2]
C	$T_2 = 100.00^\circ\text{C}$	[C1]
	$T_2 = 0.139 \text{ k}\Omega$	[C2]

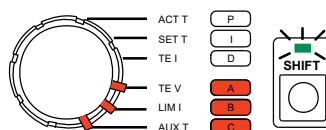

Wiring an RTD

Wire the RTD to the **Output Connector** on the rear panel. Do not exceed 1 m cable length. Refer to **Sensor Error Condition on page 28** if you can't clear a Sensor Error.

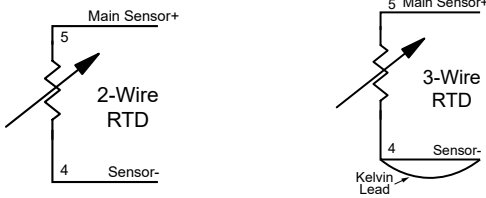

Automatic Bias Current

A fixed bias current, I_{BIAS} , flows from Pin 5, through the RTD and back into Pin 4 to produce a voltage, V_{RTD} . As the RTD resistance (R_{RTD}) changes, the voltage changes. The voltage must be between 0 and +5 V for proper operation. The LFI-3751 automatically ranges between four bias currents (10 μ A, 100 μ A, 1 mA, and 10 mA) to optimize the feedback while allowing a wider temperature range of operation. Hysteresis is designed in to produce “bumpless” operation when switching from one bias current to another.

RTD Voltage (Pins 4 & 5)

$$V_{RTD} = I_{BIAS} \times R_{RTD}$$

where V_{RTD} is the voltage across Pins 4 & 5, I_{BIAS} is the LFI bias current, and R_{RTD} is the resistance of the RTD. **Table 1** shows the Bias Current and Sensor Resistance Range.

RTD Temperature vs. Resistance

The LFI uses three data pairs to configure an RTD- **A**, **B**, and **C**. To indicate you're using an RTD, the first data pair **A** must be (1.000, 1.000). Enter **A**: (1.000, 1.000), **B**: (T_1, R_1), and **C**: (T_2, R_2) through the front panel or **[A1]**, **[A2]**, **[B1]**, **[B2]**, **[C1]**, and **[C2]** via the RS-232 interface. RTD resistance changes almost linearly with temperature. Depending on your need for accuracy, the LFI offers two methods for modeling RTDs: *Linear* or *Callendar - Van Dusen Curve fit*. **Figure 8** shows the typical resistance vs. temperature response for a RTD.

Linear RTD Configuration

The first method assumes the RTD temperature response to be linear. Enter two (Temperature, Resistance) data pairs **B**: (T_1, R_1) and **C**: (T_2, R_2). R_0 (resistance at 0°C) and alpha are calculated to derive temperature from the measured RTD resistance, R_{RTD} . All resistances are in ohms and T is in °C. *Note that R_0 is typically the resistance the RTD is known by: i.e. a “100 Ω RTD” is usually 100 Ω at 0°C.*

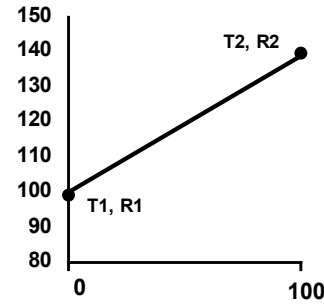

Figure 8. Typical RTD R vs. T response

Linear Configuration Constants

$$R_0 = R_2 - \frac{(R_2 - R_1)}{(T_2 - T_1)} \times T_2 \quad \text{alpha} = a = \frac{(R_2 - R_1)}{R_0 \times (T_2 - T_1)}$$

where R_0 is the RTD Resistance at 0°C, (T_1, R_1) & (T_2, R_2) are **B & C** entries, and alpha is normalized ΔR vs. Temperature.

Linear Temperature Calculations

$$T_{RTD} = \frac{(R_{RTD} - R_0)}{R_0 \times \text{alpha}}$$

where R_0 is the RTD Resistance at 0°C, R_{RTD} is the Resistance of the RTD, T_{RTD} is the Temperature of the RTD, and alpha is normalized ΔR vs. Temperature.

Callendar - Van Dusen Curve Fit RTD Configuration

For more accuracy, the RTD response can be approximated by the Callendar-Van Dusen curve fit. Most platinum RTDs follow one of three standardized curves, the DIN 43760 standard, the U.S. Industrial or American standard, or the International Temperature Scale that is used with wire-wound RTDs. The following table lists the coefficients for these three platinum RTDs.

Callendar - Van Dusen Curve Fit

$$R_T = R_0 (1 + \beta_1 T + \beta_2 T^2 + \beta_3 (T - 100)^3)$$

where R_0 is the RTD Resistance at 0°C, R_T is the Resistance of the RTD, T is the Temperature of the RTD, and $\beta_1, \beta_2, \& \beta_3$ are the Callendar - Van Dusen coefficients.

Table 2 shows the Callendar - Van Dusen Coefficients. To use these coefficients, rather than the linear configuration, certain values must be entered for **B** and **C**. The LFI-3751 will use the Callendar Van-Dusen coefficients if $T_1 = 0^\circ\text{C}$, $T_2 = 100^\circ\text{C}$, and $R_2 = \Phi R_1$. Φ is listed in **Table 2**.

Table 2. Callendar - Van Dusen Coefficients

STANDARD	Alpha	β_1	β_2	β_3	Φ
DIN 43760	0.003850	3.908×10^{-3}	-5.8019×10^{-7}	-4.2735×10^{-12}	1.39
AMERICAN	0.003911	3.9692×10^{-3}	-5.8495×10^{-7}	-4.2325×10^{-12}	1.40
ITS-90	0.003926	3.9848×10^{-3}	-5.87×10^{-7}	-4.0×10^{-12}	1.41

Table 3 shows what should be entered for a 100 Ω RTD that follows each of the standardized curves.

Table 3. Example Entries for three different standard 100 Ω RTDs

Standard	T ₁ or [B1]	R ₁ or [B2]	T ₂ or [C1]	R ₂ or [C2]
DIN 43760	0°C	0.100 kΩ	100°C	0.139 kΩ
American	0°C	0.100 kΩ	100°C	0.140 kΩ
ITS-90	0°C	0.100 kΩ	100°C	0.141 kΩ

Temperature will be calculated using the first two coefficients (β₁ & β₂). Coefficient β₃ is not used, but its absence does not introduce considerable error.

Calculate Temperature from Resistance,
Callendar - Van Dusen Curve Fit

$$T = \frac{-\beta_1 R_1 + \sqrt{(\beta_1 R_1)^2 - 4 \beta_2 R_1 (R_1 - R_{RTD})}}{2 \beta_2 R_1}$$

where R₁ is the RTD Resistance at 0°C, R_{RTD} is the Resistance of the RTD, and T is the Temperature of the RTD.

Entering Data Pair - A (Figure 9)

- Rotate the **Display Select Switch** to **A (Shift Button ON)**. The first two data pairs alternate on the display. (1.000, 1.000) indicates to the LFI that you are using an RTD.
- Rotate the **Digi-Pot Adjust Knob** to change the value displayed.
- **A, B, and C** cannot be adjusted while the output is on.
- Data pairs **A, B, and C** are saved in non-volatile memory.
- RS-232 Command: [A1] = +001.000, [A2] = +001.000

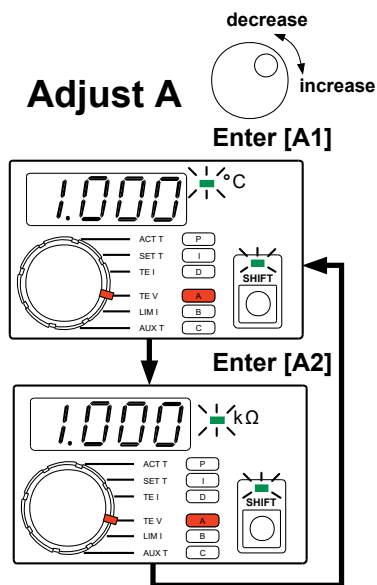

Figure 9. Entering Data Pair A - RTD

Entering Data Pairs - B & C

- To enter Data Pairs **B** and **C**, follow the instructions for **Data Pair A** but rotate the **Display Select Switch** to either **B** or **C (Shift Button ON)**. Then adjust the values as needed.
- Default from the factory sets up for a 100 Ω RTD using the DIN 43760 coefficients.
- To display RTD resistance rather than temperature, enter (0.000, 0.000) for the **B** terms. [**C** terms are ignored for resistance display.]
- RS-232 Command: [B1] = T₁, [B2] = R₁
- RS-232 Command: [C1] = T₂, [C2] = R₂
- Display Resolution is in the table below.

TEMPERATURE	-199.9 to -20.0°C
	-19.99 to -2.00°C
	-1.999 to 9.999°C
	10.00 to 99.99°C
RESISTANCE	0 to 9.999 kΩ
	10.00 to 99.99 kΩ
	100.0 to 499.9 kΩ

Displaying Actual RTD Temperature

- Rotate the **Display Select Switch** to **ACT T (Shift Button OFF)** to display the RTD temperature.
- RS-232 Command: [ACT T]

Display Resolution

-199.9 to -20.0°C
-19.99 to 99.99°C
100.0 to 199.9°C

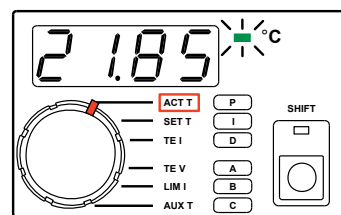

Display Actual RTD Resistance

- Enter (1.000, 1.000) for **A** and (0.000, 0.000) for **B** to have the LFI display RTD resistance (kΩ) when the **Display Select Switch** is rotated to **ACT T (Shift Button OFF)**.
- RS-232 Command: [ACT R]

Display Resolution

0 to 9.999 kΩ
10.00 to 99.99 kΩ
100.0 to 499.9 kΩ

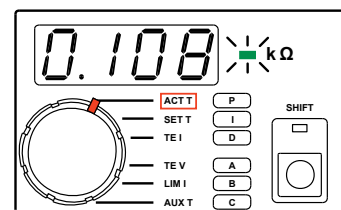

Adjusting RTD Temperature Setpoint

- Rotate the **Display Select Switch** to **SET T** (**Shift Button OFF**). Temperature will be displayed.
- To adjust the setpoint, rotate the **Digi-Pot Adjust Knob**. While the knob is rotating, the display will change, but the instrument will not control to the new setpoint until the knob stops moving.
- The decimal point will move to display maximum resolution.
- **SET T** is saved in non-volatile memory.
- **RS-232 Command:** [SET T]

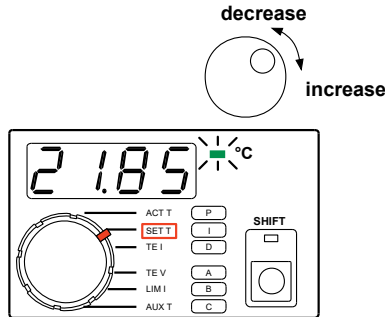

Adjusting RTD Resistance Setpoint

- Rotate the **Display Select Switch** to **SET T** (**Shift Button OFF**). If (1.000, 1.000) has been entered for **A**, and (0.000, 0.000) has been entered for **B**, resistance will be displayed.
- To adjust the setpoint, rotate the **Digi-Pot Adjust Knob**. While the knob is rotating, the display will change, but the instrument will not control to the new setpoint until the knob stops moving.
- The decimal point will move to display maximum resolution.
- **SET R** is saved in non-volatile memory.
- Temperature Limits are disabled in Resistive Operating Mode.
- **RS-232 Command:** [SET R]

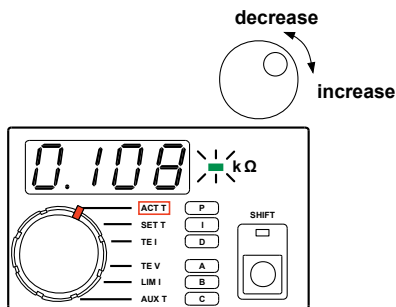

CONTROLLING TEMPERATURE WITH AD590s

Key to accurately measuring and controlling temperature with an AD590 is properly entering the configuration data. An AD590 is a current source with an output current that varies linearly with temperature. To indicate to the LFI that the sensor is an AD590, **A** = (2.000, 2.000). To characterize the linear response, the LFI-3751 requires a **Slope** and **Offset**. For the AD590, **B** = **Slope** and **C** = **Offset**. With this information, the LFI-3751 can calculate temperature from AD590 current and properly calculate the setpoint current from the setpoint temperature.

Default AD590 Configuration

A	= 2.000	[A1]
	= 2.000	[A2]
B Slope	= 1.000 μA / K	[B1]
C Offset	= 0.00 μA	[C1]

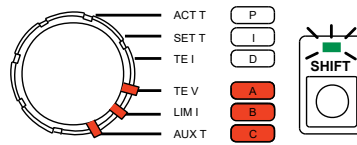

Wiring an AD590

Wire the AD590 to the **Output Connector** on the rear panel. Do not exceed 1 m cable length. Refer to **Sensor Error Condition** on page 28 if you can't clear a Sensor Error.

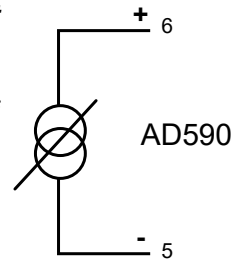

Temperature vs. AD590 Current

An AD590 is a current source with an output current that varies linearly with temperature. The LFI-3751 requires a **Slope** and **Offset** to model this response mathematically. To indicate you're using an AD590, **A** = (2.000, 2.000). To configure its response, **B** = **Slope**, and **C** = **Offset**. Typically the **Slope** is 1 μA / Kelvin and the **Offset** is 0 μA.

Enter **A**: (2.000, 2.000), **B**: **Slope**, and **C**: **Offset** through the front panel or [A1], [A2], [B1], and [C1] via the RS-232 interface.

AD590 Temperature

$$T = \frac{I_{AD590} - b_{AD590}}{m_{AD590}} - 273.15$$

where T is the AD590 Temperature (°C), I_{AD590} is the AD590 Current, m_{AD590} is the AD590 Slope, and b_{AD590} is the AD590 Offset.

Entering Data Pair - A

- Rotate the **Display Select Switch** to **A (Shift Button ON)**. The first two data pairs alternate on the display. (2.000, 2.000) indicates to the LFI-3751 that you're using an AD590.
- Rotate the **Digi-Pot Adjust Knob** to change the value displayed.
- **A, B, and C** cannot be adjusted while the output is on.
- Data for **A, B, and C** are saved in non-volatile memory.
- RS-232 Command: **[A1] = +002.000, [A2] = +002.000**

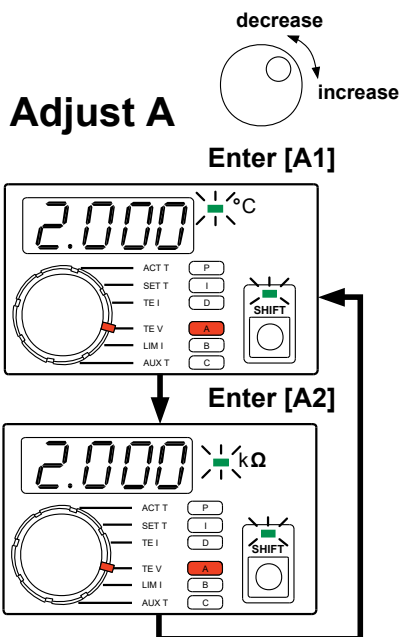

Displaying Actual AD590 Temperature

- Rotate the **Display Select Switch** to **ACT T (Shift Button OFF)** to display the AD590 temperature.
- RS-232 Command: **[ACT T]**

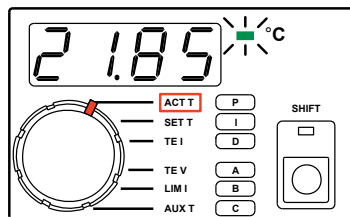

Display Resolution

-199.9 to	-20.0 °C
-19.99 to	99.99 °C
100.0 to	199.9 °C

Adjusting AD590 Temperature Setpoint

- Rotate the **Display Select Switch** to **SET T (Shift Button OFF)**. Temperature will be displayed.
- To adjust the setpoint, rotate the **Digi-Pot Adjust Knob**. While the knob is rotating, the display will change, but the instrument will not control to the new setpoint until the knob stops moving.
- The decimal point will move to display maximum resolution.
- **SET T** is saved in non-volatile memory.
- RS-232 Command: **[SET T]**

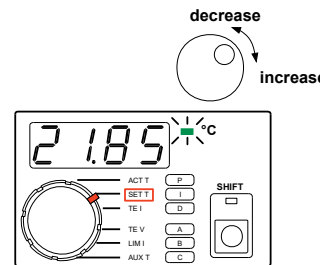

Entering Data Pairs - B & C

- To enter Data Pairs **B** and **C**, follow the instructions for **Data Pair A** but rotate the **Display Select Switch** to either **B** or **C (Shift Button ON)**.
- Rotating the **Display Select Switch** to **B (Shift Button ON)** will display the AD590's **Slope** in $\mu\text{A} / \text{Kelvin}$.
- Rotating the **Display Select Switch** to **C (Shift Button ON)** will display the AD590's **Offset** in μA .
- Rotate the **Digi-Pot Adjust Knob** to change the value. Factory default for **B** is $1 \mu\text{A} / \text{K}$, and the factory default for **C** is $0 \mu\text{A}$.
- **A, B, and C** cannot be adjusted while the output is on.
- Data for **A, B, and C** are saved in non-volatile memory.
- RS-232 Command: **[B1] = Slope, [C1] = Offset**

Display Resolution:

SLOPE	0.100 to 9.999 $\mu\text{A} / \text{K}$
OFFSET	-99.9 to 99.9 μA

CONTROLLING TEMPERATURE WITH A LM335

Key to accurately measuring and controlling temperature with an LM335 is properly entering the configuration data. An LM335 produces a voltage that changes linearly with temperature. To indicate to the LFI-3751 that the sensor is an LM335, **A = (3.000, 3.000)**. To characterize the linear response, the LFI-3751 requires a **Slope** and **Offset**. For the LM335, **B = Slope** and **C = Offset**. With this information, the LFI can calculate temperature from LM335 voltage and properly calculate the setpoint voltage from the setpoint temperature.

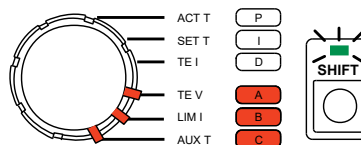

Default LM335 Configuration

A	= 3.000	[A1]
	= 3.000	[A2]
B Slope	= 10.00 mV / K	[B1]
C Offset	= 0.0 mV	[C1]

Wiring an LM335

Wire the LM335 to the **Output Connector** on the rear panel. Do not exceed 1 m cable length. Refer to **Sensor Error Condition on page 28** if you can't clear a Sensor Error.

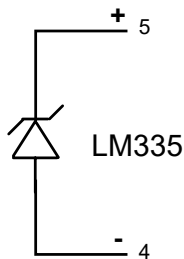

Temperature vs. LM335 Voltage

The LM335 produces a voltage that changes linearly with temperature in Kelvin. The LFI requires a **Slope** and **Offset** to model this response mathematically. To indicate you're using an LM335, **A** = (3.000, 3.000). To configure the response, **B** = **Slope** and **C** = **Offset**.

Enter **A**: (3.000, 3.000), **B**: **Slope**, and **C**: **Offset** through the front panel or **[A1]**, **[A2]**, **[B1]**, and **[C1]** via the RS-232 interface.

$$T = \frac{V_{LM335} - b_{LM335}}{m_{LM335}} - 273.15$$

LM335 Temperature

where T is the LM335 Temperature (°C), V_{LM335} is the Voltage across Pins 4 & 5, m_{LM335} is the LM335 **Slope** (10 mV / Kelvin), and b_{LM335} is the LM335 **Offset** (0 mV).

Entering Data Pair - A

- Rotate the **Display Select Switch** to **A** (**Shift Button ON**). The first two data pairs alternate on the display. (3.000, 3.000) indicates to the LFI that you're using an LM335.
- Rotate the **Digi-Pot Adjust Knob** to change the value displayed.
- **A**, **B**, and **C** cannot be adjusted while the output is on.
- Data for **A**, **B**, and **C** are saved in non-volatile memory.
- RS-232 Command: **[A1]** = +003.000, **[A2]** = +003.000

Entering Data Pairs - B & C

- To enter Data Pairs **B** and **C**, follow the instructions for **Data Pair A** but rotate the **Display Select Switch** to either **B** or **C** (**Shift Button ON**).
- Rotating the **Display Select Switch** to **B** (**Shift Button ON**) will display the LM335's **Slope** in mV / Kelvin, rotating to **C** will display the **Offset** in mV.
- Rotate the Digi-Pot Adjust Knob to change the value. Default from the factory sets up for a 10 mV / Kelvin slope and a 0 mV Offset.
- RS-232 Command: **[B1]** = **Slope**, **[C1]** = **Offset**

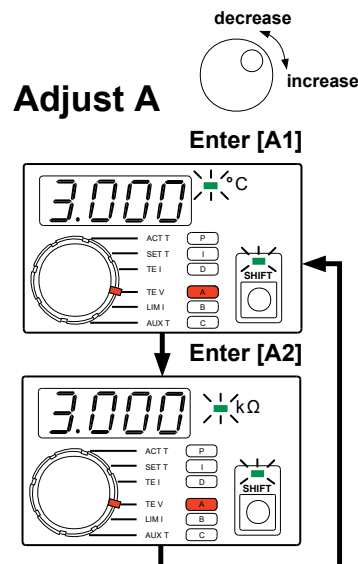

Display Resolution:

SLOPE	0.10 to 20.00 mV / K
OFFSET	-99.9 to 99.99 mV

Displaying Actual LM335 Temperature

- Rotate the **Display Select Switch** to **ACT T** (**Shift Button OFF**) to display the LM335 temperature.
- RS-232 Command: **[ACT T]**

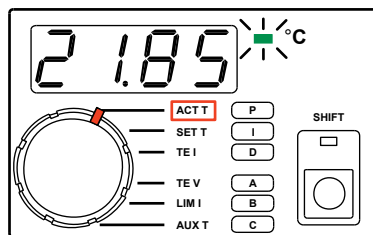

Display Resolution

-199.9 to	-20.0 °C
-19.99 to	99.99 °C
100.0 to	199.9 °C

Adjusting LM335 Temperature Setpoint

- Rotate the **Display Select Switch** to **SET T** (**Shift Button OFF**). Temperature will be displayed.
- To adjust the setpoint, rotate the **Digi-Pot Adjust Knob**. While the knob is rotating, the display will change, but the instrument will not control to the new setpoint until the knob stops moving.
- The decimal point will move to display maximum resolution.
- **SET T** is saved in non-volatile memory.
- RS-232 Command: **[SET T]**

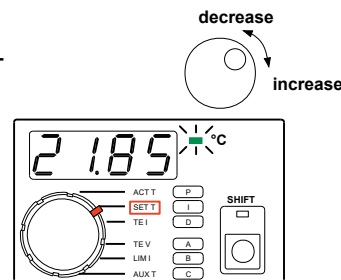

AUTOTUNE PID OPERATION

The LFI-3751 is capable of automatically characterizing your thermoelectric or resistive heater load and calculating optimum control loop settings for **P**, **I**, and **D**.

Autotune Process - During an Autotune, the LFI-3751 measures the load's thermal lag time, L , the maximum Temperature versus Time slope, R_{max} , and the load's thermal time constant, T , for a given output step current, $TE I$. This can be seen in **Figure 10**.

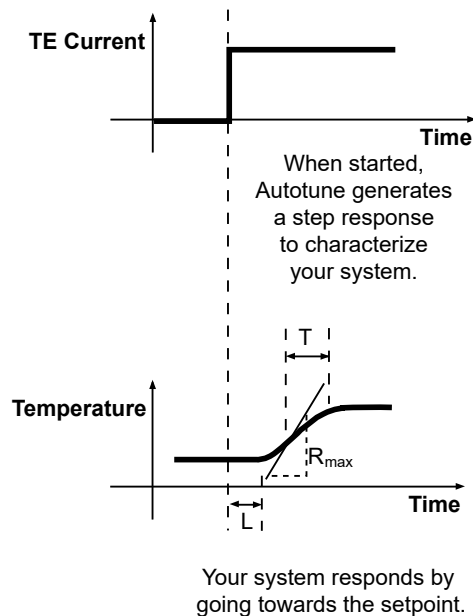

Figure 10. Autotune Process

The time to complete an Autotune Optimization varies from load to load. The process occurs in three phases as seen in **Figure 11**:

Phase 1: The LFI-3751 ramps the thermoelectric current to drive the thermal load temperature toward the setpoint temperature.

Phase 2: The LFI-3751 performs three characterization passes.

Phase 3: The LFI-3751 reverts to normal operation, saving the optimized P, I, and D settings in non-volatile memory and settling in at the setpoint temperature.

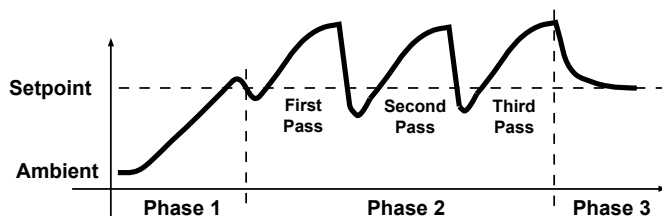

Figure 11. Autotune Process

Preliminary Considerations - Before performing an Autotune, certain parameters must be set. Here are five items to consider before you start an Autotune sequence.

A. Current Limit Setting

- Make sure the LIM I setting does not exceed the maximum TE I rating for your thermoelectric.
- In Phase 1 of an Autotune sequence, the initial TE current is 10% of the limit current setting. If the ramp rate decreases, the current will be increased in 10% increments to maintain the ramp rate until the load reaches the setpoint temperature.
- The LFI-3751 will display Error 2 (E002) when the temperature setpoint cannot be reached using the TE Current Limit setting.

B. Temperature Limit Setting

- The Autotune sequence will abort if the thermal load temperature exceeds either temperature limit.
- Resolution: While completing the Autotune, reduce the TE Current Limit or if your thermal load can withstand higher or lower temperatures, then increase the Temperature Limit settings.

C. Setpoint Temperature

- Autotune will optimize the control parameters around the setpoint (SET T) that you have selected.
- In temperature mode for thermistors, the controller will capture the information used to calculate the control parameters. When you change your setpoint, the Autotune feature will automatically recalculate the PID terms for the new setpoint.
- If your temperature limits and the SET T temperature are too close (within about 5°C), the sequence will probably reach the temperature limit and abort.

D. If an active device is under temperature control

- Avoid applying power to temperature sensitive devices during the Autotune sequence because extreme temperature fluctuations may occur.
- Apply steady state power to the device for the best Autotune results.

E. Choosing the control loop method

- If you are in an electrically noisy environment, don't use the **D** term. Use only the **P & I** terms.
- Generally, it is best to choose **PID** control and let the LFI-3751 determine your control loop method.
- For slow thermal loads that cycle around the setpoint even after **PI** or **PID** Autotune, select **P** or **PD** for the control loop. Note: **P** or **PD** control loops will not settle the load temperature at SET T and will also result in setpoint inaccuracy.

Choose an Autotune method - There are two Autotune optimization selections available: **Setpoint Response Tuning** and **Disturbance Rejection Tuning**.

Setpoint Response Tuning is valuable when continuously stepping the LFI-3751 from one temperature to another. Your system will go to temperature quickly and settle in with little or no overshoot, shown in **Figure 12**.

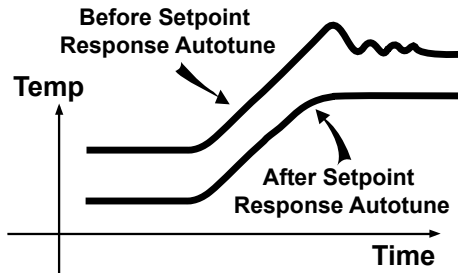

Figure 12. Setpoint Response Autotune Method

Disturbance Rejection Tuning is valuable when your thermal load is exposed to varied environmental conditions, such as air currents or ambient temperature fluctuations. It also improves temperature stability in applications where the device being temperature controlled experiences significant power or heat transients, such as those found in pulsed laser diode applications.

When a system is optimized for Disturbance Rejection, it is not optimized for Setpoint Response and vice versa. More simply, a thermal load that is optimized to reject disturbances will often overshoot and ring when changing from one setpoint temperature to the next. This method is shown in **Figure 13**.

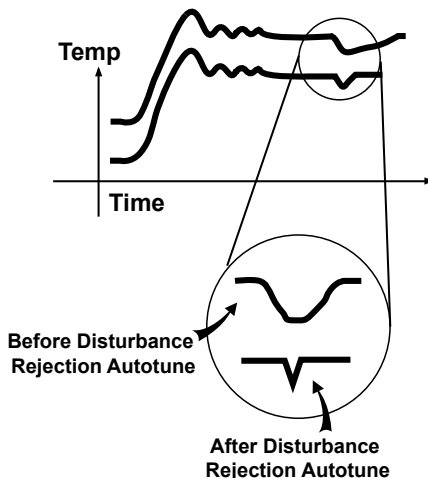

Figure 13. Disturbance Rejection Autotune Method

NOTE: Sometimes thermal loads behave in a manner referred to as a “non-minimum phase system” or more simply, the initial response of the system is to move in the opposite direction of the desired temperature change. When the LFI-3751 performs a Setpoint Response Autotune, it assumes the thermal load is a single pole system. The right-hand plane zero is not compensated for and the load temperature will still overshoot. In most cases where the thermal load exhibits this behavior, the Autotune removes the majority of the overshoot and still improves the settling time performance. This is seen in **Figure 14**.

If your thermal load exhibits a non-minimum phase response, do not optimize with Disturbance Rejection Autotuning.

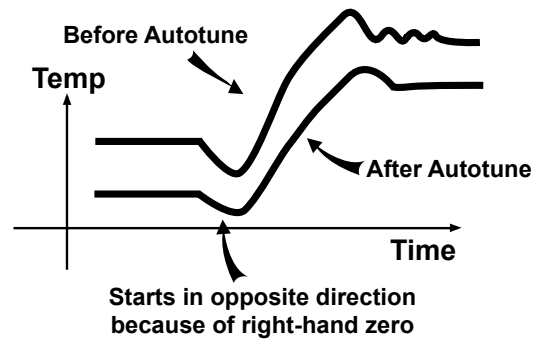

Figure 14. Non-minimum Phase System

Configure LFI-3751 for Autotune

A. Setpoint Response Tuning (Figure 15)

- Rotate the **Display Select Switch** to **P (Shift Button ON)**.
- While the output current is disabled, rotate the **Digi-Pot Adjust Knob** counter-clockwise to change the value displayed to AutS. Wait about two seconds before starting an Autotune sequence.
- Rotate the **Display Select Switch** to **I (Shift Button ON)**.
- Rotate the **Digi-Pot Adjust Knob** to change the value displayed. If $I = 0$, Autotune will optimize your system without an integrator. If $I \neq 0$, Autotune will optimize your system with an integrator function.
- Rotate the **Display Select Switch** to **D (Shift Button ON)**.
- Rotate the **Digi-Pot Adjust Knob** to change the value displayed. If $D = 0$, Autotune will optimize your system without a differentiator. If $D \neq 0$, Autotune will optimize your system with the differentiator function.
- Refer to **page 63** for a discussion on the integrator and differentiator functions.
- **RS-232 Command:** [P], [I], [D]

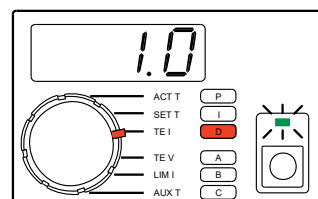
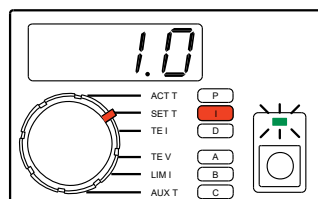
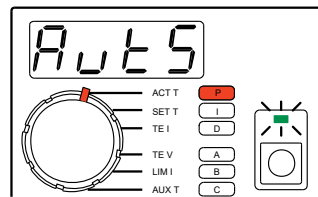

Figure 15. Setpoint Response Tuning

B. Disturbance Rejection Tuning (Figure 16)

- Rotate the **Display Select Switch** to **P (Shift Button ON)**.
- While the output current is disabled, rotate the **Digi-Pot Adjust Knob** counter-clockwise to change the value displayed to Autd. Wait about two seconds before starting an Autotune sequence.
- Rotate the **Display Select Switch** to **I (Shift Button ON)**.
- Rotate the **Digi-Pot Adjust Knob** to change the value displayed. If $I = 0$, Autotune will optimize your system without an integrator. If $I \neq 0$, Autotune will optimize your system with an integrator function.
- Rotate the **Display Select Switch** to **D (Shift Button ON)**.
- Rotate the **Digi-Pot Adjust Knob** to change the value displayed. If $D = 0$, Autotune will optimize your system without a differentiator. If $D \neq 0$, Autotune will optimize your system with the differentiator function.
- Refer to **page 63** for a discussion on the integrator and differentiator functions.
- **RS-232 Command:** [P], [I], [D]

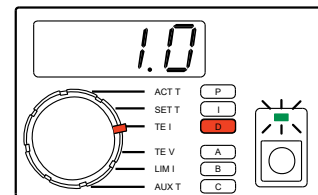
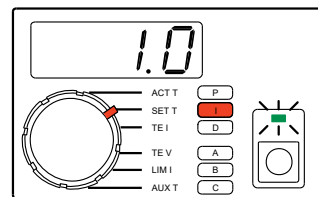
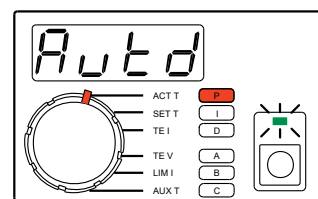
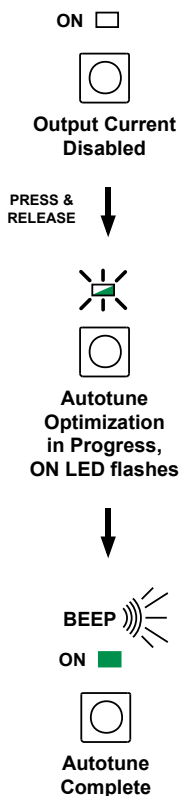

Figure 16. Disturbance Rejection Tuning

Start Autotune Optimization

- Prior to enabling current, the thermoelectric and sensor must be wired to the LFI-3751 output connector, and the current and temperature limits must be set.
- Press the **Output Button** to enable current flow and start the Autotune optimization through the thermoelectric (or resistive heater). The **Output LED** will flash green.
- When the Autotune is complete, the unit will beep once and the **Output LED** will light solid green. The new **P**, **I**, and **D** settings are written to non-volatile memory.
- **RS-232 Command:** **[RUN / STOP]**



Manually Abort Autotune Optimization

- To abort the Autotune, press the **Output Button** once.
- The unit will beep three times.
- The **Output LED** turns off, and current flow is disabled.
- The **P**, **I**, and **D** settings are returned to values set before starting Autotune.

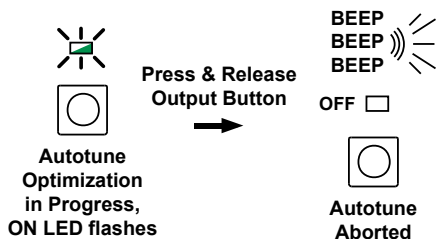

Autotune Error Codes

Four error conditions can occur that will abort the Autotune sequence. When an error occurs, the error is displayed as follows. The error is also returned in the **[RUN / STOP]** RS-232 command:

E001 – Error 1: Zero Value Current Limit Error

- The LFI-3751 detected that either the required positive or negative current limit was set to zero. The LFI-3751 cannot drive the temperature toward the setpoint.
- Correction: Set the limit to something other than zero.

E002 – Error 2: Current Limit Cannot Reach SET T

- The LFI-3751 determined the current limit is not high enough to reach the desired operating temperature entered in SET T.
- Correction: Increase the current limit or review the design to see why the desired temperature differential cannot be achieved.

E003 – Error 3: Non-uniform TE I Step Measured

- It is critical that the step current, TE I, remain constant throughout the Autotune parameter measurements for **L**, **R_{MAX}**, and **T**. If the output current is limited because the compliance voltage of the LFI-3751 has been reached, the step current will not be uniform.
- Correction: Reduce the current limit or use a thermoelectric with a lower voltage requirement.

E004 – Error 4: Zero Slope

- The load temperature is not changing over time. Either the sensor signal is not changing, no current is flowing to the thermoelectric, or even with the maximum current flowing to the thermoelectric the load temperature is not changing.
- Correction: Verify that the sensor is in good thermal contact with the load and that it is properly wired to the LFI Output Connector. Verify that the thermoelectric is properly wired to the LFI Output Connector.

SENSOR ERROR CONDITION

- The **Sensor Error LED** flashes red and the unit beeps whenever the sensor error condition occurs. The output is forced OFF.
- If you correct the error condition then press the **Output Button** to clear the error, the instrument will beep three times to indicate that the error is cleared. Once the error is cleared, press the **Output Button** to re-enable the current.
- If the error condition has not been corrected, when you press the **Output Button** to clear the error, the instrument will sound one long beep. As long as the error condition has not been corrected, pressing the **Output Button** will produce the long beep. If the error condition is corrected, when you press the **Output Button**, the unit will beep three times to indicate the error has been cleared. Press the **Output Button** again to turn on the output current.
- The sensor error condition is triggered by a sensor signal that is either too high or too low a voltage. **Table 4** indicates where each sensor will trigger a sensor error.

Sensor Error LED flashes when sensor is shorted or open. One long beep sounds if error has not been corrected after pressing the **Output Button**.

Table 4. Sensor Error Conditions

SENSOR	LOW SENSOR ERROR CONDITION	HIGH SENSOR ERROR CONDITION
Thermistor	≤ 0.01 V	≥ 4.99 V
RTD	≤ 0.01 V	≥ 4.99 V
AD590	≤ 0.01 V	≥ 4.99 V
LM335	≤ 0.01 V	≥ 4.99 V

SETTING LIMIT CURRENTS

To protect the thermoelectric or resistive heater, positive and negative limit currents can be set below the damage threshold.

- Rotate the **Display Select Switch** to **LIM I (Shift Button OFF)**. Current (in Amps) will be displayed. The positive limit will alternate with the negative limit. Rotating the **Digi-Pot Adjust Knob** clockwise makes the **Positive LIM I** more positive. Rotating the **Digi-Pot Adjust Knob** counter-clockwise makes the **Negative LIM I** more negative.

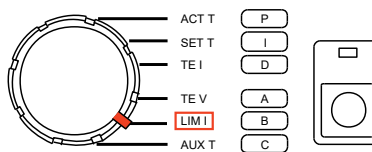
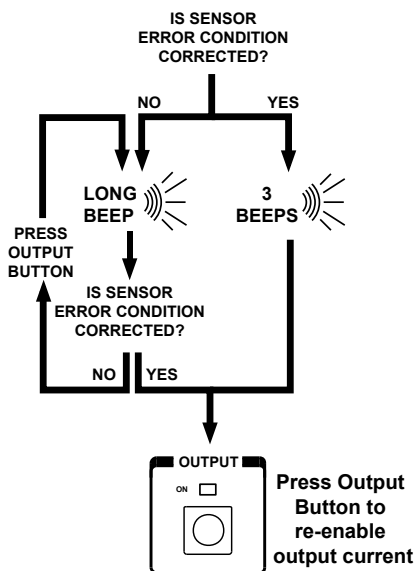
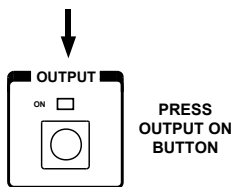
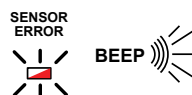

Default Limit Currents

Positive LIM I = 1.00 A
[LIM I POSITIVE]
Negative LIM I = -1.00 A
[LIM I NEGATIVE]

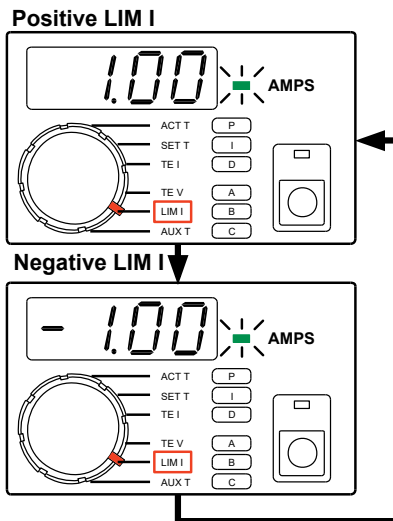

- To operate a Resistive Heater, set the **Positive Limit** to 0.00 Amps.
- The limit settings will not be updated until the Digi-Pot stops moving.
- When the output is current limited, **TE I** will be within ± 50 mA of the limit setting.
- **LIM I** settings are saved in non-volatile memory.
- When the setpoint and actual temperature are different, the LFI-3751 drives current to the thermoelectric or resistive heater until the load approaches the setpoint temperature. Sometimes the output current is driven up to the limit current settings (indicated by the **LIM I LED** flashing). A lower Limit Current will increase the settling time since less power is delivered to the thermoelectric (or resistive heater).
- The **LIM I LED** in the Status Section flashes when the maximum current (positive or negative) is being sourced to the thermoelectric or resistive heater.
- RS-232 Command: **[LIM I POSITIVE], [LIM I NEGATIVE]**

LIM I LED flashes when Positive or Negative Limit is reached

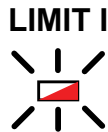

Display Resolution

POSITIVE LIM I	0.00	to	+5.00 A
NEGATIVE LIM I	-5.00	to	0.00 A

SETTING TEMPERATURE LIMITS

If the thermoelectric or resistive heater drives the load temperature beyond the temperature limits, the output will shut off and the **T LIMIT LED** will flash.

- Press and release the **TEMP LIMIT Button**. The high and low limits will alternate on the display three times before reverting to the **Display Select Switch** selection.
- Rotate the **Digi-Pot Adjust Knob** to change the value displayed.
- The LFI-3751 uses the lowest number as the Low Temperature LIMIT and the highest number as the High Temperature LIMIT.
- The temperature limits will not be updated until the Digi-Pot stops moving.
- The **T LIMIT LED** in the Status Section lights solid red

- to indicate the limits are displayed and can be adjusted.
- The Temperature Limits are disabled when thermistors or RTDs are configured to display resistance rather than temperature.
- **High Temp Limit** and **Low Temp Limit** settings are saved in non-volatile memory.
- If you push and release the **TEMP LIMIT Button** or rotate the **Display Select Switch** while displaying the temperature limits, the display will revert to the prior **Display Select Switch** selection.
- If the **T LIMIT LED** flashes and the unit beeps, the load temperature has exceeded one of the limits. The output is forced off. Press the **Output Button** to clear the error. If cleared, the unit beeps three times. Press the **Output Button** again to re-enable output current. If the error persists, the unit will sound a long beep. Once the error is corrected, you can press the **Output Button** to re-enable output current.
- RS-232 Command: **[T LIM HIGH], [T LIM LOW]**

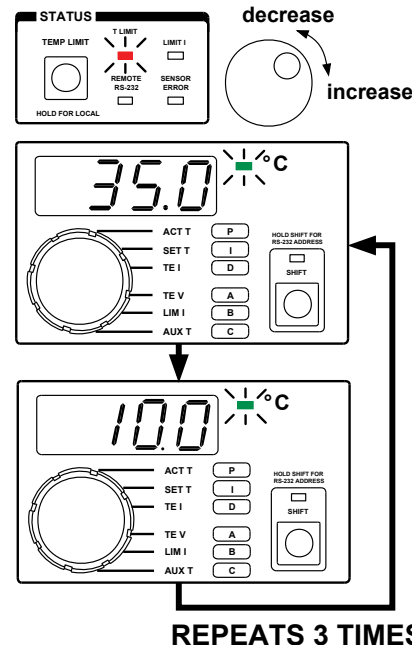

REPEATS 3 TIMES

Default Temperature Limits

HIGH TEMP LIMIT	= 35.0°C
	[T LIM HIGH]
LOW TEMP LIMIT	= 10.0°C
	[T LIM LOW]



T LIMIT LED flashes when load temperature exceeds either High or Low Limit Temperature. One long beep sounds if error has not been corrected after pressing the **Output Button**.

MANUALLY SETTING THE P, I, AND D CONSTANTS

Selecting optimum PID control parameters that minimize overshoot and maximize stability is even easier now when using the LFI-3751 with Autotune PID. Refer to **Autotune PID Operation on page 24** for a detailed description of the Autotune feature. The LFI-3751 can be configured to operate as a **P**, **PI**, **PD**, or **PID** temperature controller.

The following sections discuss how to manually adjust the **P**, **I**, and **D** constants.

Display Proportional Gain

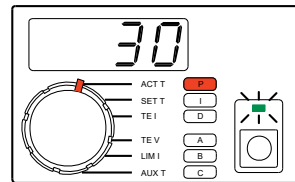
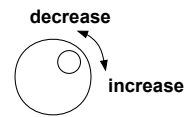

Adjusting the I Term

- For most small loads, set the Proportional Gain to 30, the Integral Time Constant to 1 second, and Differentiator Time Constant to OFF (0).
- The **P**, **I**, and **D** settings are saved in non-volatile memory.
- When first controlling a load, adjust only the **P** term while leaving the **I** term at 1 second and the **D** term OFF. If the load will not stabilize for any **P** term, then increase the **I** term to 2 seconds. Again, adjust the **P** term to optimize the system. Repeat these steps until the load temperature stabilizes around the setpoint temperature. Use the **D** term to reduce overshoot and to damp the system.

- Rotate the **Display Select Switch** to **I** (**Shift Button ON**).
- Rotate the **Digi-Pot Adjust Knob** to change the displayed value.
- RS-232 Command: **[I]**
- Increasing the integrator time constant will improve the instrument's control loop stability (especially with large thermal loads). Increasing the integrator too much produces a sluggish response and long settling times. If you notice the temperature of your load slowly approaching the setpoint temperature, then reduce the integrator time constant. Reducing the integrator too much can cause thermal cycling.

Default P, I, & D Constants

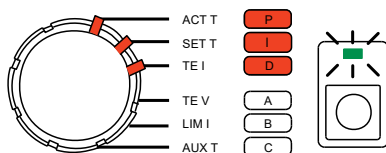

P	= 30	[P]
I	= 1 second	[I]
D	= 0 (OFF)	[D]

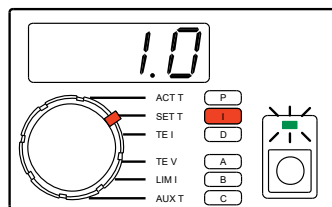

Integral Time Constant Range

OFF	0.0
ON	0.4 to 10 seconds

Adjusting the P Term

- Rotate the **Display Select Switch** to **P** (**Shift Button ON**).
- Rotate the **Digi-Pot Adjust Knob** to change the displayed value.
- The Proportional Gain range is AutS, Autd, and 0 to 100.
- RS-232 Command: **[P]**
- Increasing the proportional gain will improve overall temperature stability. Since most thermal systems are "gain limited", too high a proportional gain can cause thermal cycling or instability in the instrument's control loop. If you notice the temperature of your load cycling around the setpoint temperature, then reduce the proportional gain.

Adjusting the D Term

- Rotate the **Display Select Switch** to **D** (**Shift Button ON**).
- Rotate the **Digi-Pot Adjust Knob** to change the displayed value.
- RS-232 Command: **[D]**
- Increasing the differentiator time constant also improves the instrument's control loop stability. The differentiator term is typically only useful or necessary for large, hard to control thermal loads. The differentiator term can amplify electrical noise from the sensor. If you notice the temperature of your load quickly cycling then reduce the differentiator time constant.

Proportional Gain Range

AUTO SETPOINT	AutS
AUTO DISTURBANCE	Autd
OFF	0.0
ON	0.1 to 100

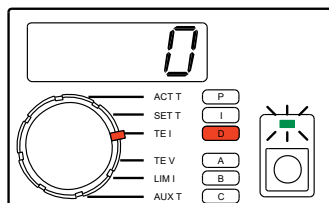

Differentiator Time Constant Range

OFF	0.0
ON	1 to 100 seconds

SETTING OPERATING TEMPERATURE OR RESISTANCE SETPOINT

- Rotate the **Display Select Switch** to **SET T (Shift Button OFF)**. Temperature (or resistance) will be displayed.
- To adjust the setpoint, rotate the **Digi-Pot Adjust Knob**. While the knob is rotating, the display will change, but the instrument will not control to the new setpoint until the knob stops moving.
- The decimal point will move to display maximum resolution.
- **SET T** or **SET R** is saved in non-volatile memory.
- RS-232 Command: **[SET T]**, **[SET R]**

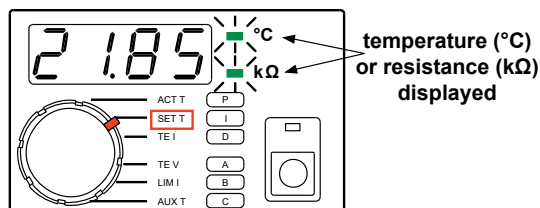
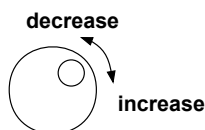
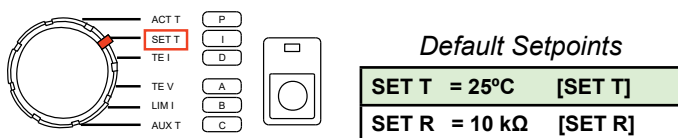

Display Resolutions

ALL SENSORS	TEMPERATURE	-199.9 to -20.0°C
		-19.99 to 99.99°C
		100.0 to 199.9°C
THERMISTOR & RTD (In Resistance MODE)	RESISTANCE	0 to 9.999 kΩ
		10.00 to 99.99 kΩ
		100.0 to 499.9 kΩ

ENABLING OUTPUT CURRENT

Wiring the Output Connector

- Wire the thermoelectric or resistive heater to the **Output Connector** on the rear panel with at least 20 gauge wire. Do not exceed 1 m cable length. Refer to **Sensor Error Condition on page 28** if you can't clear a Sensor Error.
- Select your sensor and refer to the appropriate section on Controlling Temperature with that sensor.

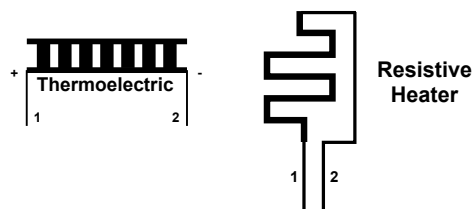

Adjusting Current and Temperature Limits

- Do not enable current until all the Current Limits, Temperature Limits, and Setpoint are adjusted for your application. See **page 28** for Current Limits, **29** for Temperature Limits, and **31** for Setpoint.

Enabling Output Current

- Press the **Output Button** to enable current flow through the thermoelectric (or resistive heater). The **Output LED** will light solid green.
- Expect the actual temperature to change in the direction of the setpoint and then stabilize.
- RS-232 Command: **[RUN / STOP]**

Disabling Output Current

- Press the **Output Button** to disable current flow through the thermoelectric (or resistive heater). The **Output LED** turns **OFF**.
- RS-232 Command: **[RUN / STOP]**

Clearing Error Conditions

- If the Temperature Limits are exceeded or a Sensor Error occurs, the **T LIMIT LED** or **SENSOR LED** will flash red and the output will turn off. Once the error condition is corrected, press the **Output Button** to clear the error. If successfully cleared, you will hear three beeps. Press the **Output Button** again to re-enable the output current. If the error condition was not corrected, you'll hear one long beep. Pressing the **Output Button** then will produce the long beep until you clear the error. Once the error is cleared, pressing the **Output Button** will enable current.

MEASURING THERMOELECTRIC CURRENT AND VOLTAGE

Measuring Thermoelectric Current

- Rotate the **Display Select Switch** to **TE I (Shift Button OFF)**.
- Current (in Amps) will be displayed with 10 mA resolution.
- The output current is limited by the positive and negative limit currents to -5.00 to +5.00 Amps.
- When the output is disabled, **TE I** will display a small current of up to ± 0.08 Amps. This small current is being supplied to the output. Do not remove the output connector until AC power to the unit is removed.
- RS-232 Command: **[TE I]**

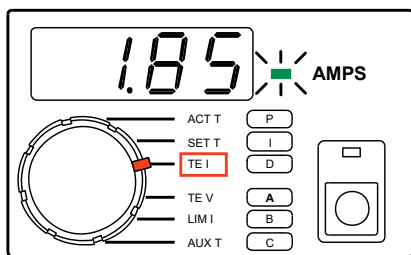

Measuring Thermoelectric Voltage

- Rotate the **Display Select Switch** to **TE V (Shift Button OFF)**.
- Voltage (in Volts) will be displayed with 0.1 V resolution.
- The measured voltage across pins 1 & 2 can range from -15.00 to +15.00 V.
- The measurement display assumes using the Wavelength cable which uses one meter of 20 AWG wire.
- With a load, up to ± 0.2 V will be displayed when the output is disabled. Without a load, approximately ± 11 V will be displayed.
- RS-232 Command: **[TE V]**

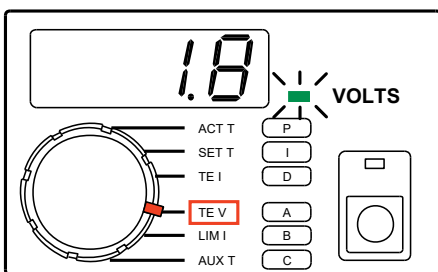

MEASURING AUXILIARY THERMISTOR TEMPERATURE

This sensor input is available to monitor the temperature of an auxiliary zone (e.g. heatsink or ambient). It is calibrated to the TCS-610 10 k Ω thermistor and uses a 100 μ A bias current. The temperature range of this sensor is -8 $^{\circ}$ C to +150 $^{\circ}$ C. Only temperature can be displayed.

Wiring the Output Connector

Wire the thermistor to the output connector on the rear panel.

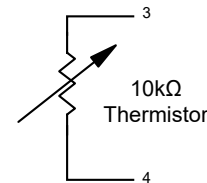

For Wavelength's thermistors, Temperature vs. Resistance charts can be found in the thermistor datasheets: www.teamwavelength.com/download/Datasheets/TCS-series-thermistors.pdf

Displaying Auxiliary Temperature

- Rotate the **Display Select Switch** to **AUX T (Shift Button OFF)** to display the auxiliary sensor temperature.
- The decimal point position changes automatically to display maximum resolution.
- If not installed, four dashes will be displayed "----".
- RS-232 Command: **[AUX T]**

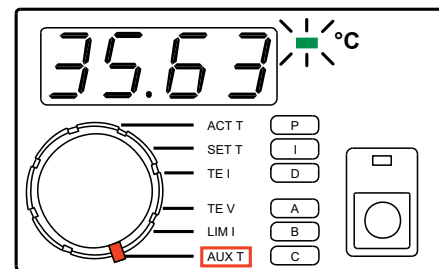

Display Resolution

-199.9 to	-20.0 $^{\circ}$ C
-19.99 to	99.99 $^{\circ}$ C
100.0 to	199.9 $^{\circ}$ C

SETTING THE RS-232 ADDRESS

Default Address

RS-232 address: 01

- Press and hold the **Shift Button**. After three seconds, the RS-232 address will be displayed.
- The **REMOTE RS-232 LED** will light solid to indicate the address is displayed and can be adjusted.
- Continue to hold the **Shift Button** and rotate the **Digi-Pot Adjust Knob** to change the value from 1 to 99.
- Release the **Shift Button** to save the displayed RS-232 address.
- The RS-232 address can only be changed via the front panel.

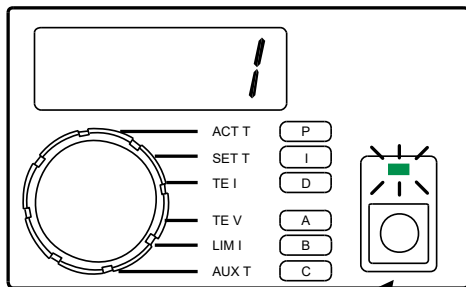
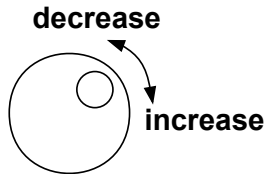
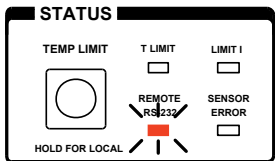

Hold in for 3 seconds

Release the **SHIFT Button** to save the displayed RS-232 address.

OPERATING WITH RESISTIVE HEATERS

Resistive Heater operation is similar to operation with thermoelectrics except only heating current is delivered to a resistive heater.

- The LFI-3751 can be configured to deliver only heating current by adjusting the **Positive Current Limit** to 0.00 Amps.
- Since the LFI-3751 has a limited output voltage of 9.5 Volts at 5 Amps, select a low value resistive heater to use the maximum power from the LFI-3751.

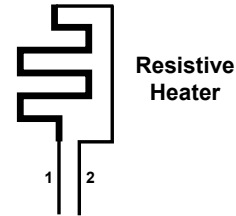

REMOTE OPERATING INSTRUCTIONS

This section details the RS-232 hardware, command and response packet structure, and how to use each command. Command codes and error codes are also listed.

All example command strings assume the instrument's RS-232 address is 01.

RS-232 INTERFACE CONFIGURATION

Connect an LFI-3751 to the RS-232 interface using the 25-pin D-sub serial connector (DB-25) on the rear panel (**RS-232 Input Connector**). You can add up to 98 more LFI-3751s by connecting the **RS-232 Output Connector** on the rear panel of the first unit to the **RS-232 Input Connector** on the rear panel of the second and so on (daisy chain configuration). The temperature controller is **not** configured as a Data Terminal Equipment (DTE) device. If your serial port is configured as a DTE device, you do not need a null modem to communicate with the LFI-3751. The LFI-3751 uses software XON/XOFF flow control.

RS-232 CONFIGURATION OVERVIEW

- Communication conforms to the RS-232C interface specifications.
- Up to 99 temperature controllers can be connected to each RS-232 port on the host computer.
- Cable length should not exceed 15 meters between computer and LFI-3751 or between two LFI-3751s.
- Use shielded, twisted pair cables (AWG 28 minimum).
- The communications specifications of the LFI-3751 are fixed. Set the host computer to match the specifications listed in the table below.

RS-232 Communication Settings

PARAMETER	SETTING
Baud Rate	19.2 kbps
Bit Length	8 Bit
Parity	No Parity
Stop Bit	1 Stop Bit

I. CONNECTIONS TO A COMPUTER

- Pins 5, 6, 8, and 20 on the LFI **RS-232 Input Connector** are shorted at the connector to ensure that the computer serial port is properly configured to transmit and receive data. Pin 4 on the 9 pin D-Sub male plug (*Data Terminal Ready Out*) provides the appropriate handshaking to the computer's *Data Carrier Detect In* (Pin 1), *Data Set Ready In* (Pin 6), and *Clear to Send In* (Pin 8).
- Pins 5, 6, 8, and 20 on the LFI **RS-232 Input Connector** do not connect to any internal circuitry.

Refer to **Cabling specifications on page 68** for connections between the LFI and computer as well as multiple LFIs.

2. CONTROLLING MULTIPLE INSTRUMENTS VIA RS-232

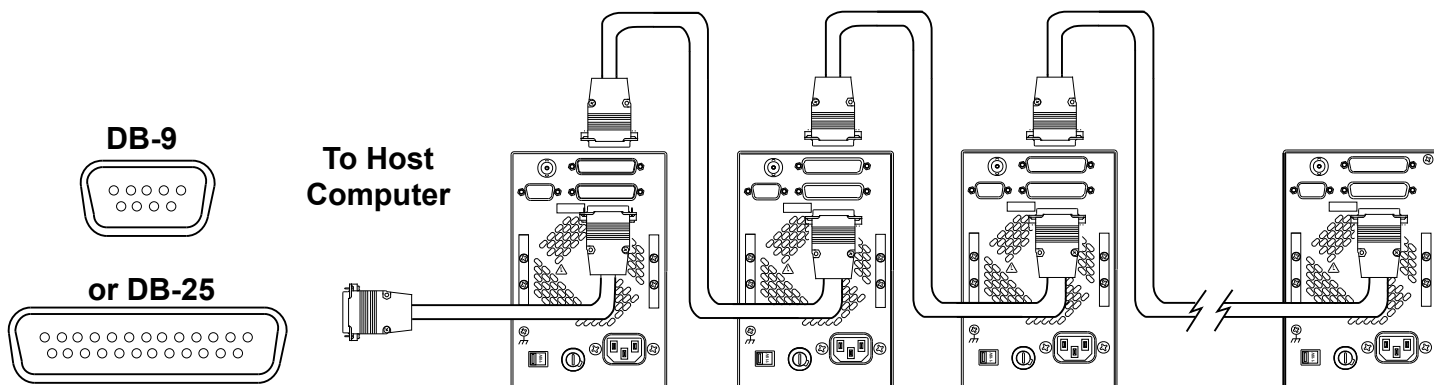

3. RS-232 CONNECTOR PINOUTS

RS-232 Input
(25 pin female D-sub receptacle)

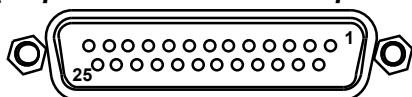

2	Instrument Receive (In)
3	Instrument Transmit (Out)
7	Signal Ground
5, 6, 8, & 20 shorted	

RS-232 Output
(25 pin male D-sub plug)

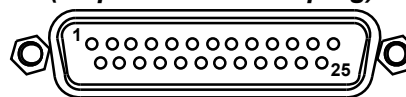

2	Peripheral Transmit (Out)
3	Peripheral Receive (In)
7	Signal Ground

RS-232 COMMAND AND RESPONSE PACKET FORMATS

- The host computer sends a *Command Packet* to the instrument and the temperature controller returns a *Response Packet* to the host computer. A *Response Packet* always returns after each *Command Packet* is sent.
- All characters in the *Command and Response Packets* are ASCII. The character fields are decimal ['0' to '9'] except for the Frame Check Sum (FCS) which is represented in HEX ['0' to '9' or 'A' to 'F'].
- The characters within the packets follow a rigid structure. The instrument's parser expects 17 characters in a *Command Packet*. Extra *Command Packet* characters will be ignored until a new start character is received. A *Response Packet* always contains 21 characters.
- READ commands (Command Type 1) do not use the data field. The data field must still contain a number between -999.999 and +999.999.
- There are no restrictions on how fast the host computer sends characters to the instrument. The packets can be sent at one character per second or using the full 19200 baud capacity. If the host computer can't buffer the instrument's *Response Packets* at full speed, configure the host computer's RS-232 port for XON/XOFF flow control.
- When a value is written to the instrument in a *Command Packet*, the corresponding *Response Packet* will return the instrument's interpretation of the value. For example, if the data field for the [SET T] *Command Packet* is +120.263, then the *Response Packet* will return +120.300 as its data field.

- The instrument's measurements are updated about every 600 milliseconds with an additional delay of about 750 milliseconds every ten minutes when the unit automatically zeros the instrument's measurement A/D. The 19.2 k BAUD rate allows Measurement Reads about every 19.8 milliseconds. The instrument returns the most recent value immediately so as not to tie up the interface in a multi-packet, multi-instrument environment. If a new measurement is required for each *Command Packet*, program in a 800 millisecond delay between *Command Packets*.
- No *Response Packet* is returned from any unit unless it at least receives a valid Start Character, a matching Unit Type and Unit Number.

COMMAND PACKET

COMMAND START	UNIT TYPE	UNIT #		COMMAND TYPE	COMMAND CODE		DATA							FCS			
!	1	X	X	X	X	X	±	X	X	X	.	X	X	X	X	X	X
							7	6	5	4	3	2	1	0			

Data Field Characters

RESPONSE PACKET

RESPONSE START	UNIT TYPE	UNIT #		COMMAND TYPE	COMMAND CODE		END CODE		DATA							FCS		CR	LF
@	1	X	X	X	X	X	X	X	±	X	X	X	.	X	X	X	X	X	

Data Field Characters

COMMAND START	!	Signifies the start of a Command Packet
RESPONSE START	@	Signifies the start of a Response Packet
UNIT TYPE [Decimal]	1 - 2	1 = Temperature Controller 2 = Laser Diode Driver
UNIT # [Decimal]	01 - 99	RS-232 address of the unit as set on the front panel of the unit (00 is reserved)
COMMAND TYPE [Decimal]	1 - 2	1 = Read data 2 = Write data
COMMAND CODE [Decimal]	00 - 99	Specifies the type of command to initiate. See "Command Code Listing" for detail
END CODE [Decimal]	00 - 99	Response indicating action success or failure. See "End Code Listing" for detail
DATA [Decimal]	±XXX.XXX	Data must match this format exactly. A sign character is followed by three digits, a decimal point, and three digits. Data is decimal and between -999.999 and +999.999
FCS [HEX]	00 - FF	Number used to check the data received and sent. See "Calculating FCS" for detail
CR LF		Carriage Return and Line Feed included in Response Packet

STANDARD COMMAND CODE LISTING

COMMAND	COMMAND TYPE	COMMAND CODE	DESCRIPTION & DATA FIELD RANGE
ACT T	1	01	Actual Temperature Measurement ^①
ACT R	1	02	Actual Sensor Resistance Measurement ^①
SET T	1 or 2	03	Temperature Setpoint: -199.900 to +199.900°C
SET R	1 or 2	04	Resistance Setpoint: +000.000 to +499.900 kΩ
TE I	1	05	Thermoelectric Current Measurement ^①
TE V	1	06	Thermoelectric Voltage Measurement
LIM I POSITIVE	1 or 2	07	Positive Current Limit: +000.000 to +005.000 Amps
LIM I NEGATIVE	1 or 2	08	Negative Current Limit: -005.000 to + 000.000 Amps
AUX T	1	09	Auxiliary Sensor Temperature Measurement
P	1 or 2	10	Proportional Gain: -002.000 Setpoint Response Autotune -001.000 Disturbance Rejection Autotune +000.000 to +100.000 Amps / Volt
I	1 or 2	11	Integral Time Constant: +000.000 = OFF or +000.400 to +010.00 sec
D	1 or 2	12	Differentiator Time Constant: +000.000 = OFF or +001.000 to +100.000 sec
A1	1 or 2	21	Sensor Configuration Term: -199.900 to +199.900°C
A2	1 or 2	22	Sensor Configuration Term: +000.000 to +499.900 kΩ
B1	1 or 2	23	Sensor Configuration Term: Range is a function of sensor. See below.
B2	1 or 2	24	Sensor Configuration Term: Range is a function of sensor. See below.
C1	1 or 2	25	Sensor Configuration Term: Range is a function of sensor. See below.
C2	1 or 2	26	Sensor Configuration Term: Range is a function of sensor. See below.
T LIM HIGH	1 or 2	31	High Temperature Limit: -199.900 to +199.900°C
T LIM LOW	1 or 2	32	Low Temperature Limit: -199.900 to +199.900°C

^① These measurement values return full floating point precision.

SENSOR TYPE	RANGE OF [B1]	RANGE OF [B2]	RANGE OF [C1]	RANGE OF [C2]
Thermistor	-199.900 to +199.900°C	+000.000 to +499.900 kΩ	-199.900 to +199.900°C	+000.000 to +499.900 kΩ
RTD	-199.900 to +199.900°C	+000.000 to +499.900 kΩ	-199.900 to +199.900°C	+000.000 to +499.900 kΩ
AD590	+000.100 to +009.999 μA / K	-	-009.990 to +009.990 μA	-
LM335	+001.000 to +020.000 mV / K	-	-009.990 to +009.990 mV	-

COMMAND	COMMAND TYPE	COMMAND CODE	DESCRIPTION AND DATA FIELD RANGE
ALARM STATUS	1	35	Char 7 = Sign Char [+ always]
			Char 6 = Sensor Open Error [0 = OK, 1 = Error]
			Char 5 = Sensor Short Error [0 = OK, 1 = Error]
			Char 4 = Low Temperature Limit [0 = OK, 1 = Error]
			Char 3 = Decimal Point
			Char 2 = High Temperature Limit [0 = OK, 1 = Error]
			Char 1 = Current Limit [0 = OK, 1 = Error]
			Char 0 = Output Status [0 = Output Off, 1 = Output On]
SENSOR BIAS CONFIGURATION To Set Sensor Bias, enter '+' in Char 7 with settings in Char 6 - 0. To Return to Auto Sensor Bias Current, enter '-' in Char 7 or turn off power.	1 or 2	41	Char 7 = Sign Char [+ = manual, - = automatic]
			Char 6 = NTC / PTC Sensor [0 = NTC, 1 = PTC]
			Char 5 = AD590 [0 = OFF, 1 = use 10 kΩ resistor for feedback]
			Char 4 = 10 mA [0 = OFF, 1 = use 10 mA bias current]
			Char 3 = Decimal Point
			Char 2 = 1 mA [0 = OFF, 1 = use 1 mA bias current]
			Char 1 = 100 μA [0 = OFF, 1 = use 100 μA bias current]
			Char 0 = 10 μA [0 = OFF, 1 = use 10 μA bias current]
MOD GAIN CONFIGURATION To Set Analog Input Gain (BNC on rear panel), enter '+' in Char 7 with settings in Char 2 - 0. To Return to Auto Analog Input Gain, enter '-' in Char 7 or turn off power.	1 or 2	42	Char 7 = Sign Char [+ = manual, - = automatic]
			Char 6 = Not Used
			Char 5 = Not Used
			Char 4 = Not Used
			Char 3 = Decimal Point
			Char 2 = Mod Gain 3 (100 : 1) [0 = OFF, 1 = ON]
			Char 1 = Mod Gain 2 (10 : 1) [0 = OFF, 1 = ON]
			Char 0 = Mod Gain 1 (1 : 1) [0 = OFF, 1 = ON]
RUN / STOP	1 or 2	51	To Enable Output or Initiate Autotune: Write data is +XXX.XX1
			To Disable Output or Abort Autotune: Write data is +XXX.XX0
			Char 5 = Autotune Error Codes 1 = Zero Value Current Limit Error 2 = Current Limit Cannot reach SET T 3 = Non-uniform TE I step measured 4 = Rate Sign Change
			Char 4 = Autotune Status [0 = Normal, 1 = Autotune]
			Char 3 = Decimal Point
			Char 2 = Temp Limit or Error Limit Status [1 = requires clearing]
			Char 1 = Integrator Status [0 = OFF, 1 = ON]
			Char 0 = Output Status [0 = OFF, 1 = ON]
LOCAL	2	53	Restore to local operation. Returns <i>Response Packet</i> as last act.
PASSWORD ②	1 or 2	54	Factory set password to access calibration and diagnostics mode. Read the current state of password flag in Char 0 0 = PASSWORD not issued; 1 = PASSWORD properly issued
SERIAL NUMBER ②	1 or 2	55	Enter or read unit serial number - PASSWORD required to enter serial number
FIRMWARE VERSION	1	56	Read firmware version.
MODEL NO. ②	1	57	Read Model Number.

② These *Command and Response Packets* violate the ±XXX.XXX data format. The data field is used for eight ASCII characters: 'XXXXXXXX'. No other commands violate the standard data format.

CALIBRATION COMMAND CODE LISTING

All WRITE *Command Packets* are PASSWORD protected.

COMMAND	COMMAND TYPE	COMMAND CODE	DESCRIPTION & DATA FIELD RANGE
10 μ A BIAS CAL	1 or 2	61	Enter actual 10 μ A sensor bias current in μ A
100 μ A BIAS CAL	1 or 2	62	Enter actual 100 μ A sensor bias current in μ A
1 mA BIAS CAL	1 or 2	63	Enter actual 1 mA sensor bias current in mA
10 mA BIAS CAL	1 or 2	64	Enter actual 10 mA sensor bias current in mA
AD590 10 k Ω CAL	1 or 2	65	Enter actual 10 k Ω resistance for sensing AD590 current in k Ω
RAW ACT T VOLT	1	71	Measure uncalibrated ACT T voltage in V
RAW TE I VOLT	1	72	Measure uncalibrated TE I voltage in V
RAW TE V VOLT	1	73	Measure uncalibrated TE V voltage in V
ACT T SLOPE CAL	1 or 2	74	Calibrate ACT T slope
ACT T OFFSET CAL	1 or 2	75	Calibrate ACT T offset
TE I SLOPE CAL	1 or 2	76	Calibrate TE I slope
TE I OFFSET CAL	1 or 2	77	Calibrate TE I offset
TE V SLOPE CAL	1 or 2	78	Calibrate TE V slope
TE V OFFSET CAL	1 or 2	79	Calibrate TE V offset
POS SET T SLOPE CAL	1 or 2	80	Calibrate positive SET T slope
POS SET T OFFSET CAL	1 or 2	81	Calibrate positive SET T offset
NEG SET T SLOPE CAL	1 or 2	82	Calibrate negative SET T slope
NEG SET T OFFSET CAL	1 or 2	83	Calibrate negative SET T offset
TE POS LIM I SLOPE CAL	1 or 2	84	Calibrate LIM I POSITIVE slope
TE POS LIM I OFFSET CAL	1 or 2	85	Calibrate LIM I POSITIVE offset
TE NEG LIM I SLOPE CAL	1 or 2	86	Calibrate LIM I NEGATIVE slope
TE NEG LIM I OFFSET CAL	1 or 2	87	Calibrate LIME I NEGATIVE offset
RESTORE FACTORY CALIBRATION DEFAULTS	2	88	Resets the calibration constants to factory defaults

END CODE LISTING

END CODE	DESCRIPTION
00	Normal Ending - No errors
01	Command Type not supported (Valid values are '1' or '2')
02	Illegal ASCII digit contained in Command Code or FCS field
03	Data field Char 7 must be '+' or '-'
04	Data field Char 3 must be '.'
05	Data field Char 6, 5, 4, 2, 1, or 0 contains an illegal ASCII character (not '0' to '9')
20	Command Type not supported for Command Code (for example, executing an ACT T measurement with '2' = WRITE as Command Type)
21	PASSWORD protected data - no PASSWORD issued prior to command execution
22	Command Code not implemented
23	FCS does not match computed FCS for this Command Packet
24	Parser programming error. Please contact factory.
25	Write command requires '1' or '0' in one of the data characters. Invalid ASCII value found.
26	Query Calculation Error. Instrument unable to calculate requested measurement. Data returned is '+999.999'
27	Sensor Configuration data written while Output is on. Sensor Data unchanged.
81	RS-232 Lamp Control Write Error - Data characters not valid. One test state allowed per write. Ignoring the decimal point, data must translate to a binary value of 0, 1, 2, 4, 8, 16, or 32.

DIAGNOSTIC COMMAND CODE LISTING

COMMAND	COMMAND TYPE	COMMAND CODE	DESCRIPTION AND DATA FIELD RANGE
LAMP CONTROL To check the lamps, enter '+' in Char 7 with settings in Char 6 - 0. To return to Normal Operation, enter '-' in Char 7 or turn off power.	2	91	Turns Front Panel Lamps on and of
			Char 7 = Sign Char [+ = manual, - = automatic]
			Char 6 = Sequence Lamps [0 = OFF, 1 = Lamp ON]
			Char 5 = All Lamps ON [0 = OFF, 1 = Lamp ON]
			Char 4 = 7 Segment Displays [0 = OFF, 1 = Lamp On]
			Char 3 = Decimal Point
			Char 2 = Unit of Measure & Shift LEDs [0 = OFF, 1 = Lamp ON]
			Char 1 = Status LEDs [0 = OFF, 1 = Lamp ON]
			Char 0 = Output ON LED [0 = OFF, 1 = Lamp ON]
PUSHBUTTON SWITCH STATUS	1	92	OUTPUT, SHIFT, & TEMP LIMIT Pushbutton Status
			Char 7 = Sign Char (Not Used); Returns '+'
			Char 6, 5, 4 = (Not Used); Returns '000'
			Char 3 = Decimal Point
			Char 2 = Temp Limit Pushbutton [0 = OFF, 1 = ON]
			Char 1 = Shift Pushbutton [0 = OFF, 1 = ON]
			Char 0 = Output Pushbutton [0 = OFF, 1 = ON]
ROTARY SWITCH STATUS	1	93	Rotary Switch Status
			A '1' indicates position of rotary switch
			Char 7 = Sign Char (Not Used); Returns '+'
			Char 6 = AUX T / C
			Char 5 = LIM I / B
			Char 4 = TE V / A
			Char 3 = Decimal Point
			Char 2 = TE I / D
			Char 1 = SET T / I
Char 0 = ACT T / P			
DIGIPOT STATUS	1	94	Read Digi-Pot counter
<i>When DIGI-POT is not moving, this command clears the DIGI-POT counter. Once the DIGI-POT is moving, this command reads the DIGI-POT counter. The counter will contain the number of interrupts generated since counter was last cleared. DIGI-POT has 32 interrupts per rotation.</i>			Char 7 = Sign Char: '+' = clockwise, '-' = counterclockwise
			Char 6, 5, 4 = Integer Number of Interrupts since last cleared
			Char 3 = Decimal Point
			Char 2 = 0
			Char 1 = 0
			Char 0 = 0

STARTING RS-232 COMMUNICATION WITH THE LFI-3751

Once you have connected a computer and at least one LFI-3751, set the unit's RS-232 address from the front panel.

STEP 1 - SET RS-232 ADDRESS

- Press and hold the **Shift Button**. After three seconds, the RS-232 address will be displayed.
- The **REMOTE RS-232 LED** will light solid to indicate the address is displayed and can be adjusted.
- Continue to hold the **Shift Button** and rotate the **Digi-Pot Adjust Knob** to change the value from 1 to 99.
- Release the **Shift Button** to save the displayed RS-232 address.
- The RS-232 address can only be changed via the front panel.

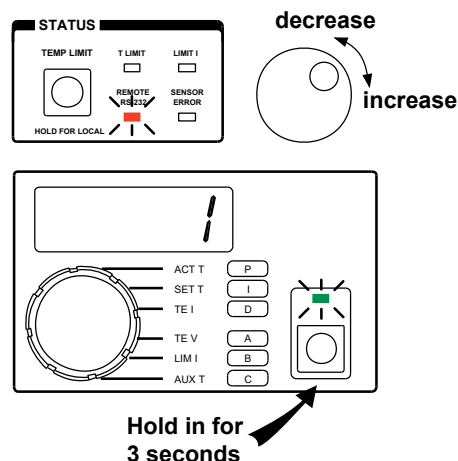

STEP 2 - SEND A COMMAND PACKET

Then, simply send a Command Packet to that instrument's address.

- The **REMOTE RS-232 LED** will flash to indicate communication is occurring. The LED will light solid if the unit has not reverted to LOCAL mode, and no communication with the host computer is ongoing.

CONFIGURING THE SENSOR

For complete detail about sensor configuration, see **Operating Instructions on page 15**.

STEP 1 - CHARACTERIZING TEMPERATURE RESPONSE

RS-232 Commands Discussed: **[A1], [A2], [B1], [B2], [C1], [C2]**

- Four or six parameters must be set depending on the type of sensor you're using: **[A1], [A2], [B1], [B2], [C1], [C2]**. **[B2]** and **[C2]** are used for thermistors and RTDs only.

EXAMPLE: To configure a thermistor, three data pairs (Temperature, Resistance) are entered to establish how the thermistor resistance changes with temperature. Six *Command Packets* are sent to configure these values. The following packets configure the instrument for a TCS-610 10 kΩ thermistor operating around 25°C. The three configuration data pairs are (10°C, 19.9 kΩ), (25°C, 10 kΩ), and (40°C, 5.326 kΩ).

<i>Write</i>	
!101221+010.00024	<i>(Sets [A1])</i>
!101222+019.90027	<i>(Sets [A2])</i>
!101223+025.00020	<i>(Sets [B1])</i>
!101224+010.00021	<i>(Sets [B2])</i>
!101225+040.00025	<i>(Sets [C1])</i>
!101226+005.32620	<i>(Sets [C2])</i>

Table 5 on page 42 details the Command Codes and expected data for all the sensors supported by the LFI-3751.

To read the current sensor configuration, the Command Type changes from a WRITE (2) to a READ (1):

<i>Read</i>	
!101221+000.00026	(Reads [A1])
!101222+000.00025	(Reads [A2])
!101223+000.00024	(Reads [B1])
!101224+000.00023	(Reads [B2])
!101225+000.00022	(Reads [C1])
!101226+000.00021	(Reads [C2])

Table 5. Command Codes and Expected Data to Configure Supported Sensors

SENSOR TYPE	RS-232 COMMAND	COMMAND CODE	DATA DESCRIPTION	DATA RANGE
THERMISTOR	[A1]	21	Temperature 1	-199.900 to +199.900°C
	[A2]	22	Resistance 1	+000.000 to +499.900 kΩ
	[B1]	23	Temperature 2	-199.900 to +199.900°C
	[B2]	24	Resistance 2	+000.000 to +499.900 kΩ
	[C1]	25	Temperature 3	-199.900 to +199.900°C
	[C2]	26	Resistance 3	+000.000 to +499.900 kΩ
RTD	[A1]	21	Sensor Type	+001.000
	[A2]	22	Sensor Type	+001.000
	[B1]	23	Temperature 1	-199.900 to +199.900°C
	[B2]	24	Resistance 1	+000.000 to +499.900 kΩ
	[C1]	25	Temperature 2	-199.900 to +199.900°C
	[C2]	26	Resistance 2	+000.000 to +499.900 kΩ
AD590	[A1]	21	Sensor Type	+002.000
	[A2]	22	Sensor Type	+002.000
	[B1]	23	Slope	+000.100 to +009.999 μA / K
	[C1]	25	Offset	-009.990 to +009.990 μA
LM335	[A1]	21	Sensor Type	+003.000
	[A2]	22	Sensor Type	+003.000
	[B1]	23	Slope	+001.000 to +020.000 mV / K
	[C1]	25	Offset	-009.990 to +009.990 mV

Sensor Data [A1], [A2], [B1], [B2], [C1], or [C2] cannot be changed while the Output is ON

STEP 2 - SELECTING AUTOMATIC OR MANUAL SENSOR BIAS

RS-232 Commands Discussed: **[Sensor Bias Configuration]**

- Each sensor type needs a different bias. **Table 6** details the typical settings for each type of sensor. See **Select a Sensor on page 16** for a thorough discussion of each sensor type.

Table 6. Typical Sensor Settings

SENSOR TYPE	NTC OR PTC SENSOR	TYPICAL BIAS CURRENT OR SENSE RESISTANCE
THERMISTOR	NTC	10 μ A or 100 μ A
RTD	PTC	1 mA or 10 mA
AD590	PTC	10 k Ω resistor across output
LM335	PTC	1 mA

- The temperature controller automatically adjusts the sensor bias current to optimize the sensor voltage and also allow a wider temperature operating range. You can control the feedback or bias current selection with the **[Sensor Bias Configuration]** Command. This command also controls the loop polarity (NTC or PTC sensor). For example, the following *Command Packet* sets the bias current to 10 μ A:

Write
!101241+000.00122 (*Sets Sensor Bias to manual 10 μ A for an NTC Sensor*)

This command is helpful for configuring the instrument for use with non-standard temperature sensors. **Table 7** details the structure of the characters in the data field.

Table 7. Character structure in the data field

Char 7 = Sign Char [+ = manual, - = automatic]
Char 6 = NTC / PTC Sensor [0 = Negative Temperature Coefficient Sensor, 1 = Positive Temperature Coefficient Sensor]
Char 5 = AD590 [0 = OFF, 1 = use 10 k Ω resistor for feedback]
Char 4 = 10 mA [0 = OFF, 1 = use 10 mA bias current]
Char 3 = Decimal Point
Char 2 = 1 mA [0 = OFF, 1 = use 1 mA bias current]
Char 1 = 100 μ A [0 = OFF, 1 = use 100 μ A bias current]
Char 0 = 10 μ A [0 = OFF, 1 = use 10 μ A bias current]

- When writing the **[Sensor Bias Configuration]** command, Character 7 (+ or -) configures the instrument to manual or automatic mode. A '+' puts the sensor configuration under manual control. A '-' lets the instrument automatically configure the sensor. When a '-' is in Character 7, Character 6 through 0 are ignored when writing.

Character 6 determines the feedback polarity. A thermistor is a Negative Temperature Coefficient Sensor. All other are Positive Temperature Coefficient Sensors.

You can combine settings to integrate a unique sensor. For example, if you need 11 mA bias current, you can set Character 4 and Character 2 to '1' to produce an 11 mA bias current.

- When reading the Sensor Bias Configuration, the Command Type changes from a WRITE (2) to a READ (1):

Read
!101141+000.00020 (*Reads [Sensor Bias Configuration]*)

This helps you determine what sensor configuration the instrument is using.

MEASURING ACTUAL TEMPERATURE OR RESISTANCE

RS-232 Commands Discussed: **[ACT T]**, **[ACT R]**

- To measure actual sensor temperature from an instrument, send the following *Command Packet*:

Read
!101101+000.00024 (Reads **[ACT T]** in °C)

- To measure actual sensor resistance from an instrument, send the following *Command Packet*:

Read
!101102+000.00027 (Reads **[ACT R]** in kΩ)

SETTING THE LIMIT CURRENTS

RS-232 Commands Discussed: **[LIM I POSITIVE]**, **[LIM I NEGATIVE]**

For complete detail about setting the Limit Current, see **page 28**.

- Separate positive and negative current limits are available: **[LIM I POSITIVE]** and **[LIM I NEGATIVE]**.

EXAMPLE: To configure the instrument with maximum currents of +1 A and -0.5 A, send the following two *Command Packets*.

Write
!101207+001.00020 (Sets **[LIM I POSITIVE]** in Amps)
!101208-000.5002D (Sets **[LIM I NEGATIVE]** in Amps)

- To read the instrument's limit current settings, the Command Type changes from WRITE (2) to a READ (1):

Read
!101107+000.00022 (Reads **[LIM I POSITIVE]** in Amps)
!101108-000.0002D (Reads **[LIM I NEGATIVE]** in Amps)

- [LIM I POSITIVE]** Ranges from +000.000 to +005.000 A.
- [LIM I NEGATIVE]** Ranges from -005.000 to +000.000 A.

TO CONFIGURE FOR A RESISTIVE HEATER

- Set **[LIM I POSITIVE]** to +000.000 A to operate a resistive heater.

SETTING TEMPERATURE LIMITS

RS-232 Commands Discussed: **[T LIM HIGH]**, **[T LIM LOW]**

For complete detail about setting the Temperature Limits, see **page 29**.

- Separate high and low temperature limits are available to protect your load: **[T LIM HIGH]** and **[T LIM LOW]**.

EXAMPLE: To configure the instrument with temperature limits of 50°C and 0°C, send the following two *Command Packets*.

Write

!101231+050.00021 (Sets **[T LIM HIGH]** in °C)

!101232+000.00027 (Sets **[T LIM LOW]** in °C)

- To read the current temperature limits, the Command Type changes from WRITE (2) to a READ (1):

Read

!101131+000.00027 (Reads **[T LIM HIGH]** in °C)

!101132+000.00024 (Reads **[T LIM LOW]** in °C)

- Temperature Limits range from -199.900 to +199.900°C
- The temperature limits are disabled when thermistors or RTDs are configured to display resistance rather than temperature.

AUTOTUNE PID & SETTING THE P, I, AND D CONSTANTS

RS-232 Commands Discussed: **[P]**, **[I]**, **[D]**

For complete details about Autotune PID operation, see **page 24**.

For complete details about setting the P, I, and D constants, see **page 30**.

The LFI-3751 with Autotune PID can optimize the PID control parameters to minimize temperature overshoot and reduce settling times with Setpoint Response Autotuning or to reject thermal transient effects on temperature stability by using Disturbance Rejection Autotuning.

The LFI-3751 can be configured to operate as a **P**, **PI**, **PD**, or **PID** temperature controller.

- To configure the instrument to begin an Autotune Optimization, send one of the following *Command Packets*.

Write

!101210-002.00023 (Sets **[P]** to AutS)

!101211-001.00021 (Sets **[P]** to Autd)

EXAMPLE: To configure the instrument as a Proportional (**P**) controller with P = 30, send the following *Command Packets*.

Write

!101210+030.00024 (Sets **[P]** to 30)

!101211+000.00026 (Sets **[I]** to OFF)

!101212+000.00025 (Sets **[D]** to OFF)

EXAMPLE: To configure the instrument as a **PI** controller with P = 30 and I = 1 second, send the following *Command Packets*.

Write

!101210+030.00024	(Sets [P] to 30)
!101211+001.00027	(Sets [I] to 1 second)
!101212+000.00025	(Sets [D] to OFF)

EXAMPLE: To configure the instrument as a **PD** controller with P = 30 and D = 1 second, send the following *Command Packets*.

Write

!101210+030.00024	(Sets [P] to 30)
!101211+000.00026	(Sets [I] to OFF)
!101212+001.00024	(Sets [D] to 1 second)

EXAMPLE: To configure the instrument as a **PID** controller with P = 30, I = 1 second, and D = 1 second, send the following *Command Packets*.

Write

!101210+030.00024	(Sets [P] to 30)
!101211+001.00027	(Sets [I] to 1 second)
!101212+001.00024	(Sets [D] to 1 second)

- To read the P, I, and D constants, the Command Type changes from a WRITE (2) to a READ (1):

Read

!101110+000.00024	(Reads [P])
!101111+000.00025	(Reads [I])
!101112+000.00026	(Reads [D])

- **[P]** ranges from +001.00 to +100.000.
- **[I]** ranges from OFF (+000.000) or +000.400 to +010.000 seconds.
- **[D]** ranges from OFF (+000.000) or +001.000 to +0100.000 seconds.

SETTING TEMPERATURE SETPOINT

RS-232 Commands Discussed: **[SET T]**

For complete detail about setting the Operating Temperature, see **page 31**.

EXAMPLE: To configure the instrument with a temperature setpoint of 35°C, send the following *Command Packet*:

Write

!101203+035.00023	(Sets [SET T] to 35°C)
-------------------	-------------------------------

- To read the instrument's setpoint temperature, the Command Type changes from a WRITE (2) to a READ (1):

Read

!101103+000.00026	(Reads [SET T] in °C)
-------------------	------------------------------

SETTING RESISTANCE SETPOINT

RS-232 Commands Discussed: **[A1]**, **[A2]**, **[B1]**, **[B2]**, and **[SET R]**

- To use resistance as the setpoint, you must be using a resistive sensor: thermistor or RTD. Table 4 shows the configuration settings and *Command Packets* to set the configuration for a thermistor or RTD in resistance mode.

Table 8. How to Configure Thermistor and RTD for Resistive Setpoint

SENSOR TYPE	CONFIGURATION / SETTING	COMMAND PACKET: Write
THERMISTOR	[A1] = 0	!101221+000.00025
	[A2] = 0	!101222+000.00026
RTD	[A1] = 1	!101221+001.00024
	[A2] = 1	!101222+001.00027
	[B1] = 0	!101223+000.00027
	[B2] = 0	!101224+000.00020

EXAMPLE: After the sensor is properly configured, send the following *Command Packet* to configure the instrument with a resistance setpoint of 10 k Ω :

Write
!101204+010.00023 (Sets **[SET R]** to 10 k Ω)

- To read the instrument's setpoint resistance, the Command Type changes from a WRITE (2) to a READ (1):

Read
!101104+000.00021 (Reads **[SET R]** in k Ω)

- Resistance Setpoint ranges from +000.000 to +499.900 k Ω .

ENABLING AND DISABLING THE OUTPUT CURRENT

RS-232 Commands Discussed: **[RUN / STOP]**

For complete detail about Enabling the Output Current, see **page 31**.

STEP 1 - ENABLE CURRENT

- To enable the instrument's output current send the following *Command Packet*.

Write
!101251+000.00123 (Enable Output Current)

STEP 2 - DISABLE CURRENT

- To disable the instrument's output current send the following *Command Packet*.

Write
!101251+000.00022 (Disable Output Current)

STEP 3 - MONITOR OUTPUT STATUS

- To read the output status, the Command Type changes from a WRITE (2) to a READ (1):

Read
!101151+000.00021

Table 9 details the structure of the characters returned in the data field.

Table 9. Monitor Output Status Characters Returned

Char 7 = Sign Char [always +]
Char 6 = Not Used
Char 5 = Autotune Error Code 1 = Zero Value Current Limit Error 2 = Current Limit Cannot reach SET T 3 = Non-uniform TE I step measured 4 = Rate Sign Change
Char 4 = Autotune Status [0 = Normal Operation, 1 = Autotune Operation]
Char 3 = Decimal Point
Char 2 = Temp Limit or Sensor Error Status [1 = requires clearing]
Char 1 = Integrator Status [0 = OFF, 1 = ON]
Char 0 = Output Status [0 = OFF, 1 = ON]

If Character 2 is '1', a Temp Limit or Sensor Error has occurred. The next command to enable current will clear the error without enabling current.

MEASURING THERMOELECTRIC CURRENT AND VOLTAGE

RS-232 Commands Discussed: **[TE I]** and **[TE V]**

For complete detail about measuring thermoelectric current and voltage, see **page 32**.

- To measure the thermoelectric current out of the instrument, send the following *Command Packet*.

Read
!101105+000.00020 (*Reads [TE I] in Amps*)

- To measure the thermoelectric voltage out of the instrument, send the following *Command Packet*.

Read
!101106+000.00023 (*Reads [TE V] in Volts*)

MEASURING AUXILIARY SENSOR TEMPERATURE

RS-232 Commands Discussed: **[AUX T]**

For complete detail about measuring temperature with the auxiliary sensor, see **page 32**.

- To measure temperature of the auxiliary 10 kΩ thermistor wired to the instrument, send the following *Command Packet*.

Read
!101109+000.0002C (*Reads [AUX T] in °C*)

SETTING GAIN FOR ANALOG INPUT SIGNAL (REAR PANEL BNC CONNECTOR)

RS-232 Commands Discussed: **[MOD Gain Configuration]**

- The instrument automatically sets the gain of the **Analog Input Connector** to match your sensor and bias current configuration. You can manually control the gain through the **[MOD Gain Configuration]** command. For Analog Input Gain 3, if you put in 1 Volt at the BNC, the setpoint changes 0.01 Volts.

Write

!101242+000.10021 (Sets Analog Input Gain to manual, 100 : 1)

Table 10 details the structure of the characters in the data field.

Table 10. Setting Analog Input Gain Character Structure

Char 7 = Sign Char [+ = manual, - = automatic]
Char 6 = Not Used
Char 5 = Not Used
Char 4 = Not Used
Char 3 = Decimal Point
Char 2 = Analog Input Gain 3 (100 : 1) [0 = OFF, 1 = ON]
Char 1 = Analog Input Gain 2 (10 : 1) [0 = OFF, 1 = ON]
Char 0 = Analog Input Gain 1 (1 : 1) [0 = OFF, 1 = ON]

- When writing the **[MOD Gain Configuration]** command, Character 7 (+ or -) configures the instrument to manual or automatic mode. A '+' puts the Analog Input Gain under manual control. A '-' lets the instrument automatically change the gains. When Character 7 is '-', character 6 through 0 are ignored when writing. When the gain is controlled automatically, the transfer function changes with sensor and bias.

Analog Input Transfer Functions

Thermistors & RTDs (10 μ A or 100 μ A)	10 k Ω / V
Thermistors & RTDs (1 mA or 10 mA)	100 Ω / V
LM335, AD590	10 $^{\circ}$ C / V

- To read the MOD Gain Configuration, the Command Type changes from a WRITE (22) to a READ (1):

Read

!101142+000.00023 (Reads **[MOD Gain Configuration]**)

CHECKING THE ALARM STATUS

RS-232 Commands Discussed: **[Alarm Status]**

- To monitor the status of the Sensor Error, Temperature Limits, Current Limits, and Output Current, use the **[Alarm Status]** command. To read the Alarm Status of the instrument, send the following *Command Packet*.

Read

!101135+000.00023 (Reads **[Alarm Status]**)

Table 11 details the structure of the characters in the data field.

Table 11. Alarm Status Character Structure

Char 7 = Sign Char [always +]
Char 6 = Sensor Open Error [0 = OK, 1 = Error]
Char 5 = Sensor Short Error [0 = OK, 1 = Error]
Char 4 = Low Temperature Limit [0 = OK, 1 = Error]
Char 3 = Decimal Point
Char 2 = High Temperature Limit [0 = OK, 1 = Error]
Char 1 = Current Limit [0 = OK, 1 = Error]
Char 0 = Output Current ON / OFF status [0 = OFF, 1 = ON]

REVERTING TO LOCAL MODE

RS-232 Commands Discussed: **[LOCAL]**

- To switch from computer to front panel control of the instrument, use the **[LOCAL]** command. To revert to LOCAL mode, send the following *Command Packet*.

Write
!101253+000.00020 (**[LOCAL]**)

- Before reverting to LOCAL mode, the instrument will return a *Response Packet*.

ENTERING THE PASSWORD

RS-232 Commands Discussed: **[PASSWORD]**

- Prior to writing a Calibration or Diagnostic *Command Packet*, the instrument must be given the proper password. To confirm the PASSWORD, send the following *Command Packet*. **NOTE** that the '????????' represents the eight ASCII characters in the actual password.

Write
!101254????????(FCS) (**[PASSWORD]**)

- This data field does not follow the standard format. These eight characters are only restricted to ASCII characters
- The PASSWORD can be obtained by calling Wavelength Electronics Technical Support or your local distributor.
- To read the status of PASSWORD access, send the following *Command Packet*. A '0' returned in Character 0 indicates the PASSWORD has not been issued. A '1' returned in Character 0 indicates the PASSWORD has been issued properly.

Read
!101154+000.00024 (*Reads Status of password flag*)

READING SERIAL & MODEL NUMBERS, FIRMWARE VERSION

RS-232 Commands Discussed: **[SERIAL NUMBER]**, **[FIRMWARE VERSION]**, and **[MODEL NUMBER]**

- These data fields do not follow the standard format. These eight data field characters are only restricted to ASCII characters
- To read the instrument's Serial Number, send the following *Command Packet*.

Read
!101155+000.00025 (Reads Serial Number 'XXXXXXXX')

- To read the instrument's Firmware Version, send the following *Command Packet*.

Read
!101156+000.00026 (Reads Firmware Version 'XXXXXXXX')

- To read the instrument's Model Number, send the following *Command Packet*.

Read
!101157+000.00027 (Reads Model Number 'XXXXXXXX'; should return "LFI-3751")

CALIBRATION - SENSOR BIAS CURRENT AND AD590 SENSE RESISTANCE

RS-232 Commands Discussed: **[PASSWORD]**, **[10 μ A BIAS CAL]**, **[100 μ A BIAS CAL]**, and **[1 mA BIAS CAL]**

- All sensor bias currents and the AD590 sense resistance are calibrated at the factory. To change these calibrated values, you must first send the **[PASSWORD]** command. You should not use these commands without direct supervision from Wavelength Electronics Technical Support Group.

Write
!101254????????(FCS) ([PASSWORD])

CALIBRATING THE 10 μ A REFERENCE CURRENT

EXAMPLE: If the instrument's 10 μ A reference current is actually 9.89 μ A, send the following *Command Packet* to properly calibrate the unit.

Write
!101261+009.89029 ([10 μ A BIAS CAL] in μ A)

CALIBRATING THE 100 μ A REFERENCE CURRENT

EXAMPLE: If the instrument's 100 μ A reference current is actually 99.5 μ A, send the following *Command Packet* to properly calibrate the unit.

Write
!101262+099.50027 ([100 μ A BIAS CAL] in μ A)

CALIBRATING THE 1 mA REFERENCE CURRENT

EXAMPLE: If the instrument's 1 mA reference current is actually 1.005 mA, send the following *Command Packet* to properly calibrate the unit.

Write
!101263+001.00527 ([1 mA BIAS CAL] in mA)

CALIBRATING THE 10 mA REFERENCE CURRENT

EXAMPLE: If the instrument's 10 mA reference current is actually 10.262 mA, send the following *Command Packet* to properly calibrate the unit.

Write
!101264+010.26223 ([10 mA BIAS CAL] in mA)

CALIBRATING THE 10 kΩ RESISTANCE (for AD590)

EXAMPLE: If the instrument's 10 kΩ resistance is actually 10.003 kΩ, send the following *Command Packet* to properly calibrate the unit.

Write
!101265+010.00327 ([AD590 10 kΩ CAL] in kΩ)

READING THE SENSOR BIAS CURRENT AND AD590 SENSE RESISTANCE SETTINGS

- To read the sensor bias and AD590 sense resistance settings, the Command Type changes from a WRITE (2) to a READ (1) and no **[PASSWORD]** is required:

Read

!101161+000.00022	(Reads [10 μA BIAS CAL] in μA)
!101162+000.00021	(Reads [100 μA BIAS CAL] in μA)
!101163+000.00020	(Reads [1 mA BIAS CAL] in mA)
!101164+000.00027	(Reads [10 mA BIAS CAL] in mA)
!101165+000.00026	(Reads [AD590 10 kΩ CAL] in kΩ)

CALIBRATION - ACT T, TE I, TE V UNCALIBRATED VOLTAGES

RS-232 Commands Discussed: [RAW ACT T VOLT], [RAW TE I VOLT], and [RAW TE V VOLT]

READING THE UNCALIBRATED ACT T VOLTAGE

- This command reads the uncalibrated ACT T voltage from the instrument's A/D. This command is useful for calculating the instrument's ACT T Slope and Offset. To read the uncalibrated ACT T voltage, send the following *Command Packet*.

Read
!101171+000.00023 ([RAW ACT T VOLT] in Volts)

READING THE UNCALIBRATED TE I VOLTAGE

- This command reads the uncalibrated TE I voltage from the instrument's A/D. This command is useful for calculating the instrument's TE I Slope and Offset. To read the uncalibrated TE I voltage, send the following *Command Packet*.

Read
!101172+000.00020 ([RAW TE I VOLT] in Volts)

READING THE UNCALIBRATED TE V VOLTAGE

- This command reads the uncalibrated TE V voltage from the instrument's A/D. This command is useful for calculating the instrument's TE V Slope and Offset. To read the uncalibrated TE V voltage, send the following *Command Packet*.

Read
!101173+000.00021 ([RAW TE V VOLT] in Volts)

CALIBRATION - MEASUREMENT SLOPES & OFFSETS

RS-232 Commands Discussed: [PASSWORD], [ACT T SLOPE CAL], [ACT T OFFSET CAL], [TE I SLOPE CAL], [TE I OFFSET CAL], [TE V SLOPE CAL], and [TE V OFFSET CAL]

- All measurements are calibrated at the factory. To change these calibrated values, you must first send the [PASSWORD] command. You should not use these commands without direct supervision from Wavelength Electronics Technical Support Group.

Write
!101254????????(FCS) ([PASSWORD])

CALIBRATING ACT T SLOPE & OFFSET

- These commands are used to calculate the instrument's ACT T measurement.

Write
!101274+001.00024 ([ACT T SLOPE CAL])
!101275+000.00024 ([ACT T OFFSET CAL] in Volts)

CALIBRATING TE I SLOPE & OFFSET

- These commands are used to calculate the instrument's TE I measurement.

Write

!101276+001.00026	([TE I SLOPE CAL])
!101277+000.00026	([TE I OFFSET CAL] in Amps)

CALIBRATING TE V SLOPE & OFFSET

- These commands are used to calculate the instrument's TE V measurement.

Write

!101278+001.00028	([TE V SLOPE CAL])
!101279+000.00028	([TE V OFFSET CAL] in Volts)

READING THE ACT T, TE I, TE V SLOPES AND OFFSETS

- To read the measurement calibration settings, the Command Type changes from a WRITE (2) to a READ (1) and no [PASSWORD] is required:

Read

!101174+000.00026	(Reads [ACT T SLOPE CAL])
!101175+000.00027	(Reads [ACT T OFFSET CAL] in Volts)
!101176+000.00024	(Reads [TE I SLOPE CAL])
!101177+000.00025	(Reads [TE I OFFSET CAL] in Amps)
!101178+000.0002A	(Reads [TE V SLOPE CAL])
!101179+000.0002B	(Reads [TE V OFFSET CAL] in Volts)

CALIBRATION - SET T SLOPES & OFFSETS

RS-232 Commands Discussed: [PASSWORD], [POS SET T SLOPE CAL], [POS SET T OFFSET CAL], [NEG SET T SLOPE CAL], and [NEG SET T OFFSET CAL]

- The setpoint temperature values are calibrated at the factory. To change these calibrated values, you must first send the [PASSWORD] command. You should not use these commands without direct supervision from Wavelength Electronics Technical Support Group.

Write

!101254????????(FCS)	([PASSWORD])
----------------------	--------------

CALIBRATING POSITIVE SET T SLOPE & OFFSET

- These commands calibrate the positive voltage SET T setpoints.

Write

!101280+001.0002F	([POS SET T SLOPE CAL])
!101281+000.0002F	([POS SET T OFFSET CAL] in Volts)

CALIBRATING NEGATIVE SET T SLOPE & OFFSET

- These commands calibrate the negative voltage SET T setpoints.

Write

!101282+001.0002D	([NEG SET T SLOPE CAL])
!101283+000.0002D	([NEG SET T OFFSET CAL] in Volts)

READING THE CURRENT CALIBRATION SETTINGS

- To read the current calibration settings, the Command Type changes from a WRITE (2) to a READ (1) and no [PASSWORD] is required.

Read

!101180+000.0002D	(Reads [POS SET T SLOPE CAL])
!101181+000.0002C	(Reads [POS SET T OFFSET CAL] in Volts)
!101182+000.0002F	(Reads [NEG SET T SLOPE CAL])
!101183+000.0002E	(Reads [NEG SET T OFFSET CAL] in Volts)

CALIBRATION - TE LIMIT CURRENT SLOPES & OFFSETS

RS-232 Commands Discussed: [PASSWORD], [T POS LIM I SLOPE CAL], [T POS LIM I OFFSET CAL], [T NEG LIM I SLOPE CAL], and [T NEG LIM I OFFSET CAL]

- The TE Limit Current values are calibrated at the factory. To change these calibrated values, you must first send the [PASSWORD] command. You should not use these commands without direct supervision from Wavelength Electronics Technical Support Group.

Write

!101254????????(FCS)	([PASSWORD])
----------------------	--------------

CALIBRATING LIM I POSITIVE SLOPE & OFFSET

- These commands calibrate the positive limit current settings.

Write

!101284+001.0002B	([TE POS LIM I SLOPE CAL])
!101285+000.0002B	([TE POS LIM I OFFSET CAL] in Amps)

CALIBRATING LIM I NEGATIVE SLOPE & OFFSET

- These commands calibrate the negative limit current settings.

Write

!101286+001.00029	([TE NEG LIM I SLOPE CAL])
!101287+000.00029	([TE NEG LIM I OFFSET CAL] in Amps)

READING THE CURRENT CALIBRATION SETTINGS

- To read the current calibration settings, the Command Type changes from a WRITE (2) to a READ (1) and no **[PASSWORD]** is required.

<i>Read</i>	
!101184+000.00029	(Reads [TE POS LIM I SLOPE CAL])
!101185+000.00028	(Reads [TE POS LIM I OFFSET CAL] in Amps)
!101186+000.0002B	(Reads [TE NEG LIM I SLOPE CAL])
!101187+000.0002A	(Reads [TE NEG LIM I OFFSET CAL] in Volts)

RESTORE CALIBRATION DEFAULTS

RS-232 Commands Discussed: **[PASSWORD]**, **[RESTORE FACTORY CALIBRATION DEFAULTS]**

- To issue this command you must first send the **[PASSWORD]** command. You should not use these commands without direct supervision from Wavelength Electronics Technical Support Group. To revert this instrument back to the default settings, send the following *Command Packets*.

<i>Write</i>	
!101254????????(FCS)	([PASSWORD])
!101288+000.00026	([RESTORE FACTORY CALIBRATION DEFAULTS])

- NOTICE:** This command will clear the calibration E²PROM and clear any previous calibration values. All slopes will reset to '1' and offsets to '0'. The sensor bias currents will become 10 μ A, 100 μ A, 1 mA, and 10 mA. The AD590 sense resistance returns to 10 k Ω . The serial number will revert to CALLWE.

DIAGNOSTIC - LAMP CONTROL

RS-232 Commands Discussed: **[LAMP CONTROL]**

- The **[LAMP CONTROL]** command tests whether the LEDs or 7 segment displays are properly operating.
- Six test states are provided. The following table details the structure of the characters in the data field. Only one test state is allowed per *Command Packet*. For example, you can turn on the 7 Segment Display with one *Command Packet* and the Status LEDs with a second *Command Packet*. **Table 12** shows the character structure for this command.

Table 12. LAMP CONTROL Command Character Structure

Char 7 = Sign Char ['+' = manual, '-' = automatic]
Char 6 = Sequence Lamps, Sound Beeper [0 = OFF, 1 = Lamp ON]
Char 5 = All Lamps On [0 = OFF, 1 = Lamp ON]
Char 4 = 7 Segment Displays [0 = OFF, 1 = Lamp ON]
Char 3 = Decimal Point
Char 2 = Unit of Measure & Shift LEDs [0 = OFF, 1 = Lamp ON]
Char 1 = Status LEDs [0 = OFF, 1 = Lamp ON]
Char 0 = Output ON LED [0 = OFF, 1 = Lamp ON]

EXAMPLE: To turn on an instrument's Unit of Measure & Shift LEDs, send the following *Command Packet*.

Write
!101291+000.1002F (*Turns on Unit of Measure & Shift LEDs*)

- Once the *Command Packet* is executed, the test state will be repeated until the instrument is returned to normal operation.
- To return the instrument to normal operation, either turn off the power or send a *Command Packet* with a '-' in Character 7.

DIAGNOSTIC - SWITCH STATUS

RS-232 Commands Discussed: **[PUSHBUTTON SWITCH STATUS]**, **[ROTARY SWITCH STATUS]**

OUTPUT, SHIFT, AND TEMP LIMIT PUSHBUTTON STATUS

- Table 9 details the structure of the characters in the data field for the **[PUSHBUTTON SWITCH STATUS]** command.

Table 13. PUSHBUTTON SWITCH STATUS Command Character Structure

Char 7 = Sign Char (Not Used)
Char 6 = Not Used
Char 5 = Not Used
Char 4 = Not Used
Char 3 = Decimal Point
Char 2 = Temp Limit Pushbutton [0 = OFF, 1 = ON]
Char 1 = Shift Pushbutton [0 = OFF, 1 = Lamp ON]
Char 0 = Output Pushbutton [0 = OFF, 1 = Lamp ON]

- To read the current status of the pushbutton switches, send the following *Command Packet*.

Read
!101192+000.0002E (*Reads [Pushbutton Switch Status]*)

ROTARY SWITCH STATUS

- **Table 14** details the structure of the characters in the data field for the **[ROTARY SWITCH STATUS]** command. A '1' indicates the position of the rotary switch.

Table 14. ROTARY SWITCH STATUS Command Character Structure

Char 7 = Sign Char (Not Used)
Char 6 = AUX T / C
Char 5 = LIM I / B
Char 4 = TE V / A
Char 3 = Decimal Point
Char 2 = TE I / D
Char 1 = SET T / I
Char 0 = ACT T / P

- To read the current status of the Rotary switches, send the following *Command Packet*.

Read
!101193+000.0002F (*Reads [Rotary Switch Status]*)

DIAGNOSTIC - DIGI-POT STATUS

RS-232 Commands Discussed: **[DIGIPOT STATUS]**

- The **[DIGIPOT STATUS]** command reads whether the Digi-Pot is moving clockwise or counterclockwise and quantifies how far it has rotated since it was last cleared.
- The Digi-Pot Counter increases when the Digi-Pot is moving at 32 counts per rotation.
- When the Digi-Pot is not moving, sending this command will clear the Digi-Pot Counter.
- When the Digi-Pot is moving, this command reads the Digi-Pot Counter.
- When the Digi-Pot is moving clockwise, the counter increases. When the Digi-Pot is moving counter clockwise, the counter decreases.
- **Table 15** details the structure of the characters in the data field for the **[DIGIPOT STATUS]** command.

Table 15. DIGIPOT STATUS Command Character Structure

Char 7 = Sign Char ['+' = clockwise, '-' = counterclockwise]
Char 6, 5, 4 = Integer number of counts since last cleared
Char 3 = Decimal Point
Char 2 = 0
Char 1 = 0
Char 0 = 0

- To read the current status of the Digi-Pot, send the following *Command Packet*.

Read
!101194+000.00028 (*Reads [DIGIPOT STATUS]*)

END CODE REFERENCE

00 - NORMAL ENDING

Command in the *Command Packet* has been processed correctly and *Response Packet* contains valid data. Data is not valid if any other End code is returned.

01 - COMMAND TYPE NOT SUPPORTED

Fifth character of the *Command Packet* (Command Type) contains a character other than '1' or '2'. Only 1 = Read and 2 = Write are supported Command Types.

02 - ILLEGAL ASCII DIGIT

The Command Code or FCS fields contain an illegal ASCII digit. The Command Code can accept '00' through '99'. FCS is a HEX number, so can accept '00' through 'FF'.

03 - INVALID DATA CHARACTER 7

This character must contain either '+' or '-'.

04 - INVALID DATA CHARACTER 3

This character must contain a decimal point '.'

05 - INVALID ASCII DATA CHARACTER DIGIT

Characters 6, 5, 4, 2, 1, or 0 must contain a valid ASCII digit '0' through '9'.

20 - COMMAND CODE DOES NOT SUPPORT COMMAND TYPE

Certain Command Codes can only read data and other command Codes can only write data. Some do both. For example, measurement codes are read only commands. If you send an **[ACT T]** code with a '2' in the fifth character (Command Type = WRITE), the *Response Packet* will return with this End Code.

21 - PASSWORD REQUIRED

The *Command Packet* attempts to write password protected data. The **[PASSWORD]** command must be issued first.

22 - COMMAND NUMBER NOT IMPLEMENTED

The *Command Packet* uses a Command Code that is not recognized.

23 - CALCULATED FCS DOES NOT MATCH TRANSMITTED FCS

The Frame Check Sum is used to verify proper transmission of data. If the calculated FCS does not match the transmitted FCS, either the data was corrupted in transmission or the FCS in the *Command Packet* was incorrectly calculated.

24 - PARSER PROGRAMMING ERROR

Please contact the factory if a *Response Packet* returns this End Code.

25 - INVALID DATA CHARACTER

The parser expects only a '0' or '1' in one of the data characters. Some other ASCII value was transmitted.

26 - QUERY CALCULATION ERROR

The LFI-3751 was unable to calculate the requested measurement. Data in the *Response Packet* is '+999.999'. This occurs when the sensor is open or shorted. This also occurs when the sensor is improperly configured or out of the temperature range.

27 - SENSOR DATA NOT UPDATED

Sensor configuration data cannot be changed while the Output is ON.

81 - RS-232 LAMP CONTROL WRITE ERROR

The **[LAMP CONTROL]** command allows only one test condition at a time. Only one of the data characters can be a '1'.

CALCULATING FCS

- FCS (Frame Check Sum) is used to ensure that the RS-232 transmission was not corrupted.
- The following BASIC routine calculates the FCS for a *Command* or *Response Packet*.

```

BASIC ROUTINE FOR      1110   'Copy either Command$ or Response$ into Packet$
CALCULATING FCS      1120   'Run FCS Generator routine: FCSGEN
                          1130   'For Command Packets, the routine generates the proper FCS
                          1140   'For Response Packets, the routine compares the FCS received to
                          1150   'a calculated FCS and returns the FCSVALID flag
                          1160   FCSGEN:
                          1170   FCS = 0
                          1180   FCSVALID = "TRUE"
                          1190   Input Packet$
                          1200   STARTCHAR$=MID$(Packet$,1,1)
                          1210   IF STARTCHAR$ = "!" THEN FCSLEN = LEN(Packet$)
                          1220   IF STARTCHAR$ = "@" THEN FCSLEN = LEN(Packet$) - 4
                          1230   IF STARTCHAR# <> "!" OR STARTCHAR$ <> "@" THEN FCSVALID = "FALSE"
                          1240   For IFCS=1 to FCSLEN
                          1250           FCS=FCS XOR ASC (MID$(Packet$, IFCS, 1))
                          1260   Next
                          1270   FCS$=RIGHT$("0",HEX$(FCS),2)
                          1280   IF STARTCHAR$ = "@" and FCS$ <> MID$(Packet$,18,2) THEN FCSVALID = "FALSE"

```

- The following Visual C++ routine calculates the FCS for a *Command* or *Response Packet*.

```

VISUAL C++          static BYTE ComputeFCS ( const CString& srPreFcsCmd )
ROUTINE FOR          {
CALCULATING FCS      BYTE ucFCS = 0;    // zero FCS byte
                          // For debugging: Validate CString object reference is to the first part of a Command or
                          //Response Packet
                          ASSERT( srPreFcsCmd.GetAt(0) == '!' || srPreFcsCmd.GetAt(0) == '@' );
                          ASSERT( srPreFcsCmd.GetLength() == 15 || srPreFcsCmd.GetLength() == 17 );
                          // Loop through each character of the string and 'Exclusive OR' result
                          // with next character. Byte returned should match transmitted FCS.
                          for( BYTE ucCharIdx = 0; ucCharIdx < srPreFcsCmd.GetLength(); ucCharIdx++ )
                              ucFCS ^= (BYTE) srPreFcsCmd.GetAt( ucCharIdx ) ;
                          return ucFCS;
                          }

```

srPreFcsCmd contains the *Command Packet* up to the FCS characters.

- The instrument always checks the *Command Packet's* FCS against the calculated FCS. The host computer program can use the *Response Packet's* FCS to verify proper communication from the instrument but it is not necessary.

EXAMPLE BASIC CONTROL PROGRAM FOR IBM PC COMPATIBLE MACHINES

```

1000 ' LFI-3751 RS-232 Control Program for IBM PC Compatible Machines
1001 '
1002 ' Configure the COM Port #1 for RS-232 communications with the following settings
1003 '
1004 ' Baud: 19200
1005 ' Parity: None
1006 ' Data: 8
1007 ' Stop: 1
1008 '
1009 OPEN "COM:19200,N,8,1,CD0,DS0,DS0,RB256,RS" FOR RANDOM AS #1 LEN=256
1010 '
1011 ' Get the instruments RS-232 address
1012 '
1013 PRINT "Enter instrument's RS-232 address [i.e. 01]";
1014 INPUT ADDRESS$
1015 '
1016 ' The following loop issues command packets to the instrument and prints out the
1017 ' instrument's response packets
1018 '
1019 RS232LOOP:
1020 '
1021 ' Determine if the command is a read or write command and enter a valid command
1022 ' code. Enter a valid data field.
1023 '
1024 PRINT "Enter command type [ 1 - Read , 2 - Write].";
1025 INPUT TYPES$
1026 PRINT "Enter command code:";
1027 INPUT CODE$
1028 IF TYPES$="1" THEN DATA$="+000.000"
1029 ELSE PRINT$ "Enter data [i.e. "xxx.xxx:.";:INPUT DATA$
1030 COMMAND$="!1"+ADDRESS$+TYPE$+CODE$+DATA$
1031 '
1032 ' Calculate the Frame Check Sum (FCS) for the entered command
1033 '
1034 FCS=0
1035 FOR IFCS=1 TO LEN(COMMAND$)
1036 FCS=FCS XOR ASC(MID$(COMMAND$,IFCS,1))
1037 NEXT
1038 FSC$=RIGHT$("0"+HEX$(FCS),2)
1039 '
1040 ' Issue command packet to the instrument
1041 '
1042 PRINT #1, COMMAND$+FSC$
1043 '
1044 ' Receive the response packet back from the instrument
1045 '

```

```
1046 RCNT=0
1047 RECV$=""
1048 RLOOP:
1049 '
1050 ' If the COM port buffer contains data then process data in RDATA loop otherwise
1051 ' keep track of time gone by since data has been entered into COM port buffer.
1052 '
1053 IF LOC(1) <> 0 THEN RDATA
1054 RCNT=RCNT+1
1055 '
1056 ' If no data has been entered into the COM port buffer by the time the counter RCNT
1057 ' reaches 100000 then indicate the instrument is not responding. If you receive the
1058 ' "No Response!" error too frequently then increase the error count value.
1059 '
1060 IF RCNT=100000 THEN RERROR
1061 ELSE RLOOP
1062 '
1063 ' The following loop sums the COM port buffer to create a response packet.
1064 ' If 21 characters are detected in the COM port buffer, then the response packet is
1065 ' printed to the screen.
1066 '
1067 RDATA:
1068 RECV$ = RECV$ + INPUT$(LOC(1),#1)
1069 IF LEN(RECV$) = 21 THEN REND
1070 ELSE RCNT=0: GOTO RLOOP
1071 '
1072 ' No response packet received.
1073 '
1074 RERROR:
1075 REV$ = "No Response!"
1076 '
1077 ' Print the response packet.
1078 '
1079 PRINT "Instrument's response packet is: "; RECV$
1080 '
1081 ' Send another packet or end program
1082 '
1083 PRINT "Continue [ Y or N]?";
1084 INPUT C$
1085 IF C$ = "Y" THEN RS232LOOP
1086 CLOSE #1
1087 END
```

ADDITIONAL TECHNICAL INFORMATION

THEORY OF AUTOTUNE PID

1. Proportional Gain – “P” and Autotune Optimization

The proportional gain, P , is measured in Amps Output Current per Volt Error Voltage. The Error Voltage is the difference between the LFI-3751’s Setpoint D to A and the measured sensor voltage feedback. When a difference exists between the setpoint temperature and actual temperature, the proportional gain directs the output power stage to supply an output current that is **proportional** to the difference. Unfortunately, if the Error Voltage drops to zero then so does the output current, which will cause the load temperature to fall back towards ambient. The larger the P value, the closer the proportional gain will settle the load to the desired operating temperature. Likewise, the larger the P value, the greater the tendency to cause temperature overshoot.

L and R_{max} affect the proportional gain setting P . A long thermal lag, L , decreases the proportional gain value. P also decreases when R_{max} , the maximum temperature versus time slope, is large. L and R_{max} can be seen in **Figure 17**.

Setpoint Response Tuning results in smaller P values than Disturbance Rejection Tuning because lower proportional gains produce less temperature overshoot of the setpoint temperature.

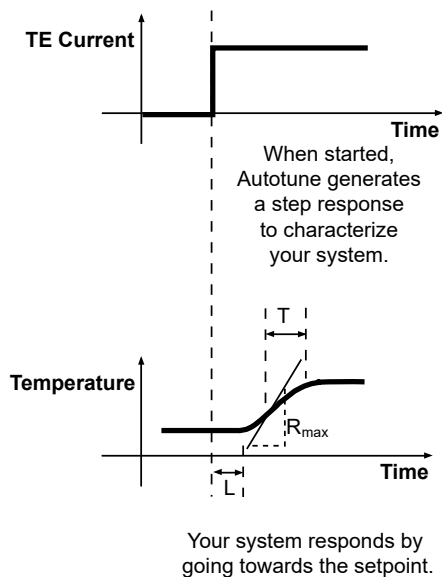

Figure 17. Autotune Theory

2. Integrator Time Constant – “I” and Autotune Optimization

The integrator time constant, I , is measured in seconds. The integrator function forces the actual temperature to stabilize at the setpoint temperature, something the proportional gain cannot do alone. This is accomplished because the integrator “integrates” the Error Voltage over time. When the actual temperature is far from the setpoint temperature, the integrator charges more quickly since the Error Voltage is large at this point. As the actual temperature approaches the setpoint temperature, the Error Voltage decreases and the integrator charges less quickly until finally the Error Voltage is zero. Once the Error Voltage is zero, the integrator stops charging and controls the output current at the necessary level to maintain a constant load temperature equal to the setpoint temperature.

Some thermal loads oscillate around the setpoint temperature. This oscillation is referred to as thermal cycling. Thermal cycling can occur if the proportional gain is greater than the system’s critical proportional gain or more commonly too small an integrator time constant has been set to compensate for the thermal load’s lag time, L . A small integrator time constant charges more quickly than a larger integrator time constant. If L is significantly larger than the integrator time constant then the integrator will force the output current to shoot past the setpoint temperature since the temperature sensor is lagging behind the thermal load’s actual temperature.

The sensor temperature eventually overshoots the setpoint temperature, forcing the integrator to charge in the opposite direction, reversing the output current. The thermal load’s lag causes an overshoot in this direction also and the cycle simply repeats itself. A large enough integrator time constant can be set to compensate for a thermal load’s lag time by charging slowly enough to not over-drive the output current. Commonly, temperature controllers will exhibit a damped oscillation when settling to temperature. This occurs because the integrator is set large enough to compensate for the thermal load’s lag time but small enough that the integrator must overshoot several times to properly balance the charge on the integrator to deliver the correct output current.

The calculated value of integrated time constant, I , depends on whether the thermal load has been optimized using Setpoint Response or Disturbance Rejection Tuning. Setpoint Response determines I from the thermal load’s time constant, T . Disturbance Rejection uses the thermal load’s lag time, L , to calculate I . Notice that T is always greater than L and so that Setpoint Response Tuning always calculates a more conservative value of I . Too large a value of I is detrimental when rejecting disturbances because a slower charging integrator will take longer to settle the load’s temperature.

3. Differentiator Time Constant – “D” and Autotune Optimization

The differentiator's time constant, D , is also measured in seconds. The differentiator uses the derivative of the Error Voltage versus time to compensate for the proportional gain's and the integrator's tendency to cause the thermal load's temperature to overshoot the setpoint temperature. To understand the differentiator, we must first examine how the proportional gain responds as the load's temperature approaches the setpoint temperature.

As long as the Error Voltage is non-zero, the proportional gain will drive the output to move the thermal load's temperature towards the setpoint temperature. The proportional gain stops driving the output current once the Error Voltage drops to zero (when the load's temperature equals the setpoint temperature). At this point, the load's thermal inertia forces it to overshoot the setpoint temperature. It is not until the Error Voltage reverses polarity that the proportional gain provides an output current that drives the actual temperature back towards the setpoint temperature, which now results in an undershoot condition.

The differentiator is dependent on the slope of Error Voltage versus time and not its magnitude. The faster a load responds, the more the differentiator forces the output current to reduce changes in the Error Voltage. Unlike the proportional gain that moves the load temperature to the setpoint temperature, the differentiator forces the output current to maintain a stable temperature or zero slope whether the load's temperature is at the setpoint temperature or not. Therefore the differentiator produces a “braking” current that resists changes to the thermal load temperature.

Obviously the differentiator should not be set so high that it counteracts the proportional gain and integrator's attempts to move the load's temperature to the setpoint temperature.

The differentiator time constant is dependent on the thermal load's lag time, L , since this parameter contributes to the integrator overshooting the setpoint temperature. A larger lag time results in a larger calculated D . The differentiator value also depends on the magnitude of proportional gain. A larger proportional gain results in a larger differentiator time constant to compensate for the proportional gain's tendency to cause overshoot.

The Setpoint Response Autotune results in smaller values for D than the Disturbance Rejection. Disturbance Rejection Autotune takes advantage of the differentiator's resistance to temperature variations at the thermal load to suppress the effects of thermal transients.

If your thermal load operates in an **electrically noisy environment**, it might be to your advantage to turn the differentiator off since the differentiator will interpret the resulting fast variations in the Error Voltage incorrectly as thermal load temperature variations. The differentiator can actually cause poorer temperature stability in this instance.

Understanding the Differentiator – A real life analogy

If you still do not understand the differentiator function, fortunately, the LFI-3751 Autotune PID eliminates the need to completely comprehend this control parameter. None the less, this following real life example may give you some insight into the differentiator. Consider the everyday situation of braking a car for a STOP sign. Imagine that the location of the STOP sign is our setpoint temperature and the location of our car is the load temperature. When we are far away from the STOP sign we step on the accelerator to quickly get to the STOP sign. This is exactly what the proportional gain portion of our brain tells us to do since we are far from our destination and want to get there as quickly as possible. The gears in our car are like the current limit function of the LFI-3751, a lower gear limits our acceleration rate towards the STOP sign and a lower current limit setting decreases how much “gas” we can apply and determines how fast we can approach the STOP sign. If we did not have a differentiator function in our brain, we would not apply the brakes until after we went through the stop sign. For most of us, we stop accelerating our car and begin applying our brakes some distance before we reach the STOP sign. This is exactly how the proportional gain and differentiator work in the PID control loop. Now imagine that the road you are driving on is covered with ice; this corresponds to thermal loads with long thermal lag times. In the case of the icy road we would stop accelerating sooner and apply the brakes for a longer period of time. Remember that a longer thermal lag time results in a smaller proportional time constant and a larger differentiator time constant.

4. Temperature Sensors and Autotune Optimization

Sensor type also affects the magnitude of the proportional gain value calculated when using Autotune optimization. For sensors with high sensitivity (a large change in sensor signal per °C), the resulting proportional gain value will be smaller than if a lower sensitivity sensor were installed into the same thermal load. Correspondingly, the integrator time constant increases when using highly sensitive temperature sensors and the differentiator time constant decreases.

Thermistors are temperature sensors that exhibit high sensitivity and therefore require less proportional gain for optimum performance. Unfortunately, thermistors only perform well over a limited temperature range and their sensor sensitivity is non-linear. This means that thermal loads using thermistors are optimally tuned around one temperature but performance degrades as the setpoint temperature is moved away from the initial tuning temperature. The LFI-3751 compensates for a thermistor's non-linear sensitivity in temperature mode by recalculating the optimum P , I , and D terms whenever the setpoint temperature is changed.

Linear sensors such as the Analog Devices AD590 and National Semiconductor LM335, and Platinum RTDs exhibit poor sensitivity and therefore require considerably higher proportional gains, but do not require recalculation of the PID terms.

5. Thermal Load Variaton and Autotune Optimization

Ideally, we would measure the load's thermal lag time, L , the maximum temperature versus time slope, R_{max} , and the load's thermal time constant, T , for a given output step current, $TE I$ at any temperature and achieve the same results. Unfortunately, most thermal loads are only linear over a small range of temperatures.

Several factors cause a thermal load to respond differently from one temperature to another. One such factor is thermoelectric efficiency, which varies depending on the current being pumped through the thermoelectric and the temperature difference between its cold and hot plate. At some point, a thermoelectric's heatsink temperature raises to a point where it absorbs heat more slowly from the thermoelectric. Both these factors affect the maximum temperature versus time slope, R_{max} .

Other factors such as ambient temperature change and power being applied to an active device affect the thermal load's lag time, L , and time constant, T . Fortunately, PID controllers are relatively robust and still control quite well even if they are not optimized. Depending on the size of your load, you may find it good practice to perform a PID Autotune each time the LFI-3751 is powered on to compensate for changes in the thermal load.

TROUBLESHOOTING

PROBLEM	POTENTIAL CAUSES	SOLUTIONS
Temperature controller does not turn on	AC Power Switch is in the OFF position	Press the AC Power Switch on the front panel to the ON position. Check that the power cord is firmly plugged into the Power Entry Module on the rear panel and check the fuse in the rear panel is in place and functional. Contact Wavelength Electronics for further instructions if the controller continues to not power on.
Temperature increases beyond the setpoint and will not come down	The TEC and heatsink are not adequately sized for the thermal load	The heat being generated by the load may be too great for the TEC to pump to the heatsink; a larger TEC or heatsink, or airflow may be needed. Consult Technical Note TN-TC01: Optimizing Thermoelectric Temperature Control Systems .
Temperature does not stabilize very well at setpoint	Poor thermal contact between components of the thermal load	Use thermal paste or washers between the load/TEC and TEC/heatsink interfaces. Make sure the temperature sensor is in good thermal contact with the load.
	Operating outside of the ideal region of the temperature sensor	The sensor type and bias current should be selected to maximize sensitivity at the target temperature. Thermistors provide the best performance, particularly for applications where a single setpoint temperature must be accurately maintained. For example, at 25°C a 10 kΩ thermistor has a sensitivity of 43 mV/°C, whereas an RTD sensor has a sensitivity of 4 mV/°C.
	Proportional control term is set too high	Run a PID Autotune scan.
	Derivative term is introducing noise.	Run a PID Autotune scan.
Using a resistive heater, temperature is slow to stabilize and is not within the specifications	Setpoint temperature is set too close to the ambient temperature	Set the temperature at least 10°C above ambient when using a resistive heater. A resistive heater is unable to precisely maintain temperatures near ambient because once the temperature overshoots the setpoint, the controller turns off and relies on ambient temperature to cool the load. If setting the temperature 10°C or more above ambient is not possible, then choose a thermoelectric, which can alternately heat and cool the load to maintain a more precise setpoint temperature.
	Airflow across load is inadequate.	Use a fan to blow air across the load to increase natural convection.
Temperature does not reach the setpoint	Insufficient current driven to the TEC or heater	Increase the current limit - but DO NOT exceed the specifications of the TEC or heater.
	The controller does not have sufficient compliance voltage to drive the TEC or heater	Check the thermoelectric voltage and determine if it is too close to the 9.5 V maximum. If it is, choose a lower voltage thermoelectric.
Actual temperature does not approach setpoint after output current is enabled	Thermoelectric wiring is reversed.	Reverse the leads to the thermoelectric.
	The thermoelectric is generating too much heat and has inadequate cooling	Install a larger heatsink or a fan to cool the heatsink.
ACT T or SET T is flashing on the display and output is locked	A, B, or C values may be invalid and the unit has found a zero or negative number in the calculations	Check the values for A, B, or C or sensor data pairs. Display will stop flashing when the unit determines the values are valid after updating the invalid value(s).

MECHANICAL SPECIFICATIONS

All dimensions are $\pm 5\%$

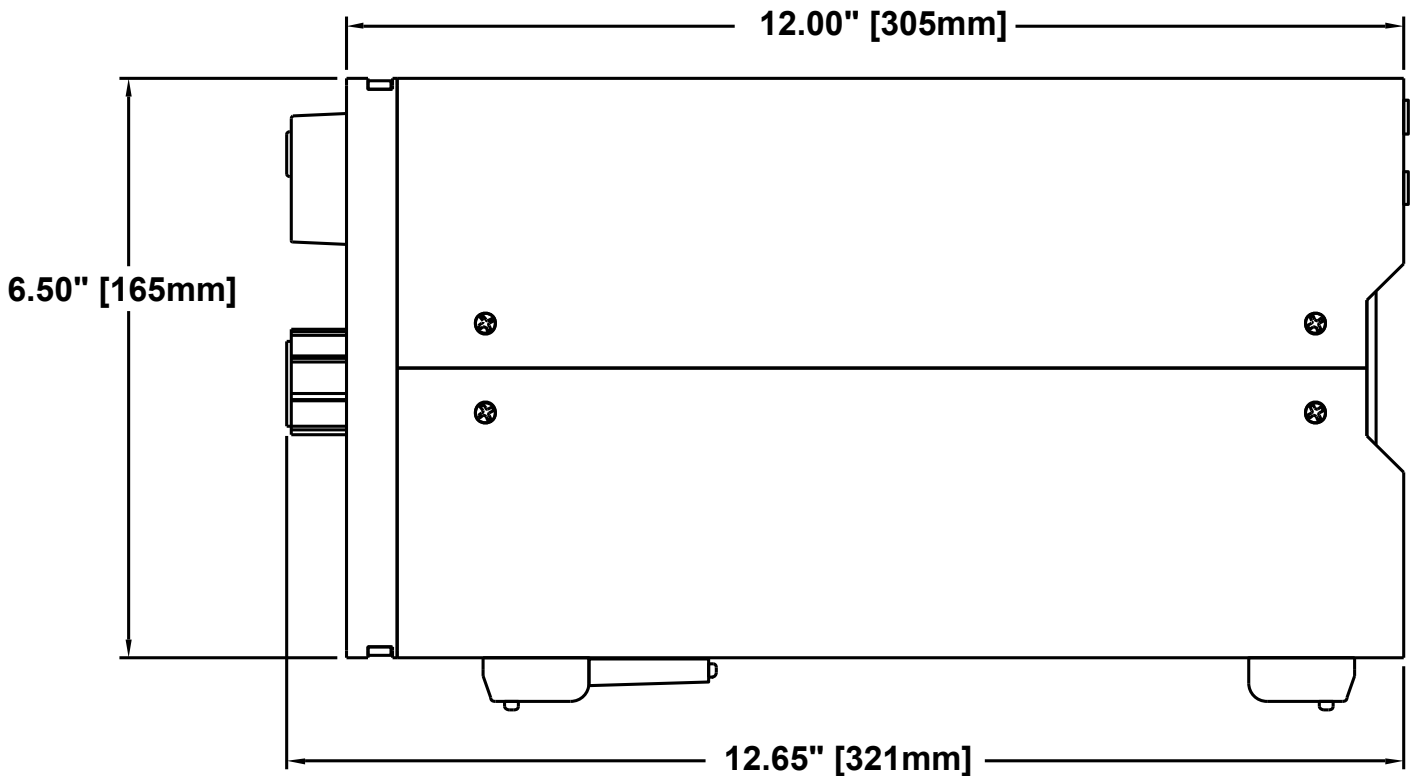
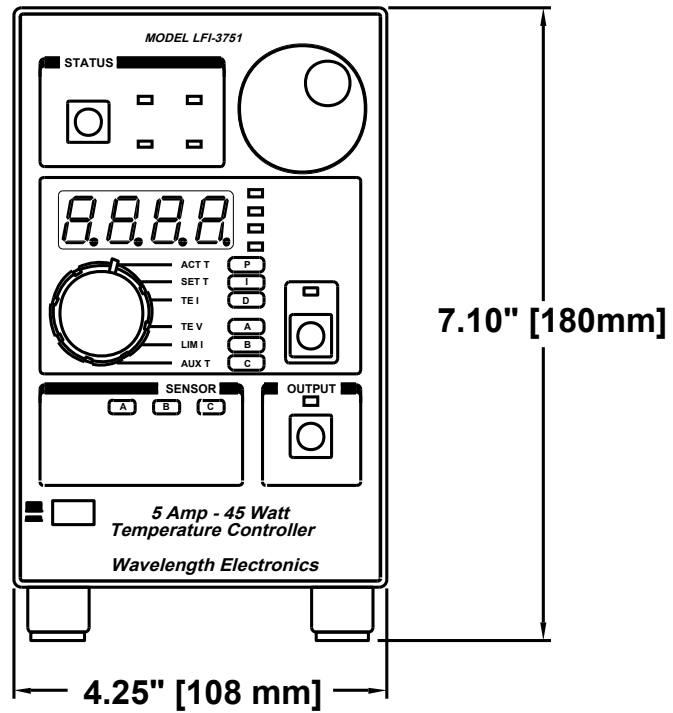

CABLING SPECIFICATIONS

These cables are not included with the LFI-3751 Temperature Controller

WCB401 RS-232 CABLE, 6-FT, DB 25-9 PIN

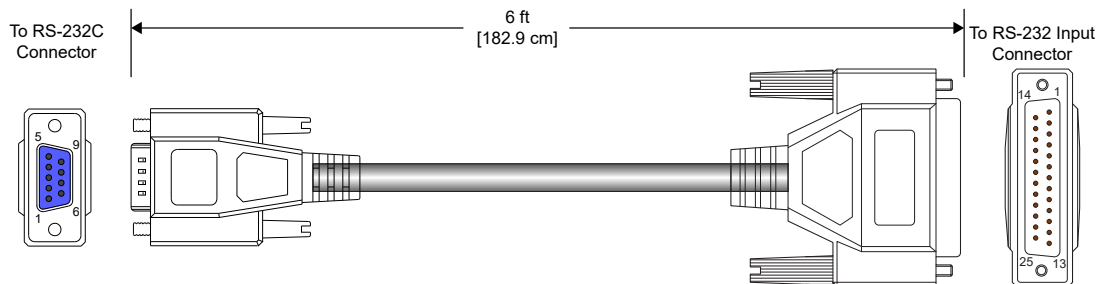

DB-9 FEMALE CONNECTOR TO HOST COMPUTER	
PIN #	FUNCTION
1	Data Carrier Detect (In)
2	Receive Data (In)
3	Transmit Data (Out)
4	Data Terminal Ready (Out)
5	Signal Ground
6	Data Set Ready (In)
7	Request to Send (Out)
8	Clear to Send (In)
9	Ring Indicator (In)
SH	D-Sub SHELL*

Pins 5, 6, 8, & 20 on the LFI **RS-232 Input Connector** are shorted at the connector. They do not connect to any internal circuitry.

*D-Sub Shell on LFI is connected to chassis. Always properly earth ground the LFI chassis through your AC power system.

DB-25 MALE CONNECTOR TO LFI-3751 (FIRST UNIT)	
PIN #	FUNCTION
2	Instrument Receive (In)
3	Instrument Transmit (Out)
5	Clear to Send (Out)
6	Data Set Ready (Out)
7	Signal Ground
8	Data Carrier Detect (Out)
20	Data Terminal Ready (In)
SH	D-Sub SHELL*

WCB402 RS-232 CABLE, 6-FT, DB 25-25 PIN

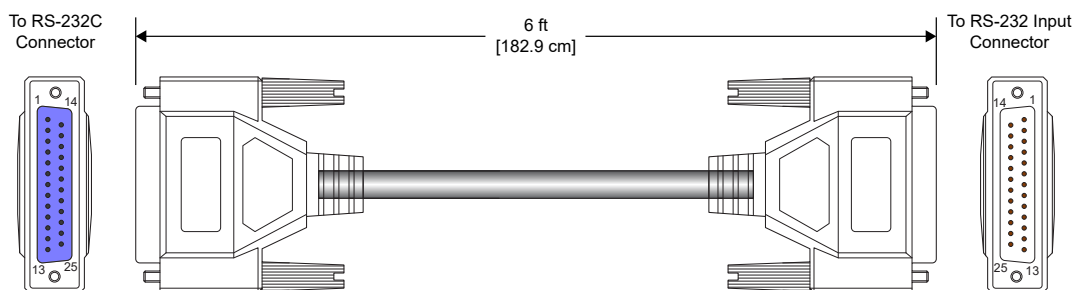

DB-25 FEMALE CONNECTOR TO HOST COMPUTER	
PIN #	FUNCTION
1	Protective Ground
2	Trasmit Data (Out)
3	Receive Data (In)
4	Request to Send (Out)
5	Clear to Send (In)
6	Data Set Ready (In)
7	Signal Ground
8	Data Carrier Detect (In)
20	Data Terminal Ready (Out)
SH	D-Sub SHELL*

Pins 5, 6, 8, & 20 on the LFI **RS-232 Input Connector** are shorted at the connector. They do not connect to any internal circuitry.

*D-Sub Shell on LFI is connected to chassis. Always properly earth ground the LFI chassis through your AC power system.

DB-25 MALE CONNECTOR TO LFI-3751 (FIRST UNIT)	
PIN #	FUNCTION
2	Instrument Receive (In)
3	Instrument Transmit (Out)
5	Clear to Send (Out)
6	Data Set Ready (Out)
7	Signal Ground
8	Data Carrier Detect (Out)
20	Data Terminal Ready (In)
SH	D-Sub SHELL*

CABLING SPECIFICATIONS

These cables are not included with the LFI-3751 Temperature Controller

WCB403 RS-232 CABLE, 2-FT, DB 25-25 PIN

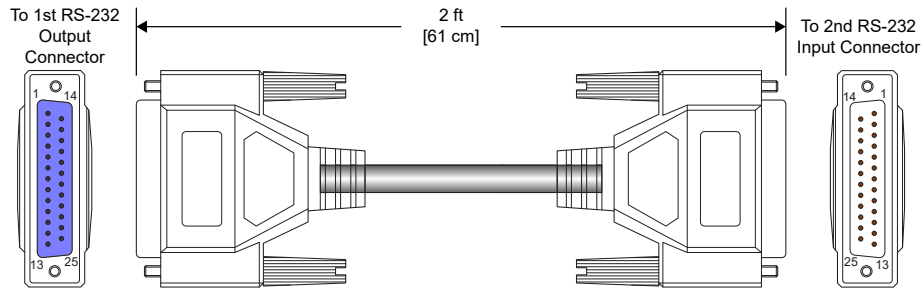

DB-25 FEMALE CONNECTOR TO LFI (FIRST UNIT)	
PIN #	FUNCTION
2	Instrument Transmit (Out)
3	Instrument Receive (In)
7	Signal Ground
SH	D-Sub SHELL*

Pins 5, 6, 8, & 20 on the LFI **RS-232 Input Connector** are shorted at the connector. They do not connect to any internal circuitry.

*D-Sub Shell on LFI is connected to chassis. Always properly earth ground the LFI chassis through your AC power system.

DB-25 MALE CONNECTOR TO LFI (SECOND UNIT)	
PIN #	FUNCTION
2	Instrument Receive (In)
3	Instrument Transmit (Out)
7	Signal Ground
SH	D-Sub SHELL*



DECLARATION OF CONFORMITY

CONFORMING PRODUCTS

MODEL NUMBER	PRODUCT
LFI3751 ANALOG	5 A, 9 V Analog Temperature Controller Instrument
LFI3751 DIGITAL	5 A, 9 V Digital Temperature Controller Instrument

DECLARATION

The undersigned hereby declares, on behalf of Wavelength Electronics, Inc. (Wavelength) of Bozeman, Montana, that the products listed in the table above, to which this Declaration applies, do not contain lead, mercury, cadmium, hexavalent chromium, polybrominated biphenyls, polybrominated diphenyl ethers or restricted phthalates, and are in conformity with the provisions of:

APPLICABLE REGULATIONS

- European Council Directive 2014/30/EC (26 February, 2014) on Electromagnetic Compatibility, tested to:
 - » IEC 61000-3-2 and IEC 61000-3-3
 - » IEC 61000-4-2, IEC 61000-4-3, IEC 61000-4-4, IEC 61000-4-5, IEC 61000-4-6, and IEC 61000-4-8
- European Council Directive 2014/35/EC (26 February, 2014) on Low-Voltage Equipment Safety, tested to:
 - » IEC 61010-1
- DIRECTIVE (EU) 2017/2102 OF THE EUROPEAN PARLIAMENT AND OF THE COUNCIL of 15 November 2017 amending Directive 2011/65/EU on the restriction of the use of certain hazardous substances in electrical and electronic equipment
- COMMISSION DELEGATED DIRECTIVE (EU) 2016/585 of 12 February 2016 amending Annex IV to Directive 2011/65/EU.
- DIRECTIVE (EU) 2015/863 of 3 June 2022 to amend Annex II to EU RoHS 3 (Directive 2011/65/EU)
- DIRECTIVE 2011/65/EU OF THE EUROPEAN PARLIAMENT AND OF THE COUNCIL of 8 June 2011 on the restriction of the use of certain hazardous substances in electrical and electronic equipment (recast) and the consolidated version of 24 June 2015
- Measures for Administration of the Pollution Control of Electronic Information Products directive of March 1, 2007

TECHNICAL FILE

The Technical Construction Files for the listed products, as required by this Declaration, are maintained at Wavelength corporate headquarters: 51 Evergreen Drive, Bozeman, Montana.

4-September-2022

Mary Johnson, CEO

Date

CERTIFICATION AND WARRANTY

CERTIFICATION

Wavelength Electronics, Inc. (Wavelength) certifies that this product met its published specifications at the time of shipment. Wavelength further certifies that its calibration measurements are traceable to the United States National Institute of Standards and Technology, to the extent allowed by that organization's calibration facilities, and to the calibration facilities of other International Standards Organization members.

WARRANTY

This Wavelength product is warranted against defects in materials and workmanship for a period of one (1) year from date of shipment. During the warranty period, Wavelength will, at its option, either repair or replace products which prove to be defective.

WARRANTY SERVICE

For warranty service or repair, this product must be returned to the factory. An RMA is required for products returned to Wavelength for warranty service. The Buyer shall prepay shipping charges to Wavelength and Wavelength shall pay shipping charges to return the product to the Buyer upon determination of defective materials or workmanship. However, the Buyer shall pay all shipping charges, duties, and taxes for products returned to Wavelength from another country.

LIMITATIONS OF WARRANTY

The warranty shall not apply to defects resulting from improper use or misuse of the product or operation outside published specifications. No other warranty is expressed or implied. Wavelength specifically disclaims the implied warranties of merchantability and fitness for a particular purpose.

EXCLUSIVE REMEDIES

The remedies provided herein are the Buyer's sole and exclusive remedies. Wavelength shall not be liable for any direct, indirect, special, incidental, or consequential damages, whether based on contract, tort, or any other legal theory.

REVERSE ENGINEERING PROHIBITED

Buyer, End-User, or Third-Party Reseller are expressly prohibited from reverse engineering, decompiling, or disassembling this product.

NOTICE

The information contained in this document is subject to change without notice. Wavelength will not be liable for errors contained herein or for incidental or consequential damages in connection with the furnishing, performance, or use of this material. No part of this document may be translated to another language without the prior written consent of Wavelength.

SAFETY

There are no user-serviceable parts inside this product. Return the product to Wavelength Electronics for service and repair to ensure that safety features are maintained.

LIFE SUPPORT POLICY

This important safety information applies to all Wavelength electrical and electronic products and accessories:

As a general policy, Wavelength Electronics, Inc. does not recommend the use of any of its products in life support applications where the failure or malfunction of the Wavelength product can be reasonably expected to cause failure of the life support device or to significantly affect its safety or effectiveness. Wavelength will not knowingly sell its products for use in such applications unless it receives written assurances satisfactory to Wavelength that the risks of injury or damage have been minimized, the customer assumes all such risks, and there is no product liability for Wavelength. Examples of devices considered to be life support devices are neonatal oxygen analyzers, nerve stimulators (for any use), auto-transfusion devices, blood pumps, defibrillators, arrhythmia detectors and alarms, pacemakers, hemodialysis systems, peritoneal dialysis systems, ventilators of all types, and infusion pumps as well as other devices designated as "critical" by the FDA. The above are representative examples only and are not intended to be conclusive or exclusive of any other life support device.

CALIBRATION INTERVAL

The customer is responsible for determining calibration intervals; however, Wavelength Electronics recommends a calibration interval of two (2) years, beginning from the original date of manufacture. The instrument's calibration can be influenced by temperature, humidity, vibration and shock, as well as general wear over time. Extending the calibration interval can lead to operation outside of specifications and is not recommended.



**WAVELENGTH
ELECTRONICS**

51 Evergreen Drive
Bozeman, Montana 59715



406-587-4910 (tel)
406-587-4911 (fax)
Sales & Tech Support
sales@teamwavelength.com
techsupport@teamwavelength.com

REVISION HISTORY

Document Number: LFI3751-00400

REV.	DATE	CHANGE
G	July 2023	Update sensor list and command list
H	Dec. 2023	Added calibration interval
I	Jan. 2024	Updated maximum output power and compliance voltage